



INDIANA DEPARTMENT OF TRANSPORTATION

100 North Senate Avenue
Room N758 CM
Indianapolis, Indiana 46204

www.in.gov/indot

Eric Holcomb, Governor
Mike Smith, Commissioner

AGENDA

January 18, 2024, Standards Committee Meeting

MEMORANDUM

January 3, 2024

TO: Standards Committee

FROM: Scott Trammell, Secretary

RE: Agenda for the January 18, 2024, Standards Committee Meeting

A Standards Committee meeting is scheduled for 09:00 a.m. on Thursday, January 18, 2024, will be held virtually via *Teams* (Microsoft application). Please contact Scott Trammell (stammell@indot.in.gov) for instructions on how to join this event.

The following items are listed for consideration:

A. GENERAL BUSINESS

OLD BUSINESS

(No items on this agenda)

NEW BUSINESS

1. *Approval of the Minutes from the [November 17, 2023](#) meeting*

B. CONCEPTUAL PROPOSAL

(No items on this agenda)

C. STANDARD SPECIFICATIONS, SPECIAL PROVISIONS, AND STANDARD DRAWINGS PROPOSAL

OLD BUSINESS

(No items on this agenda)

NEW BUSINESS

Item No. 1	Mr. White	pg. 4
2024 Standard Specifications 703.06	Placing and Fastening	
Item No. 2	Mr. Boruff	pg. 8
Recurring Special Provisions: 801-x-xxx 801-x-xxx 801-x-xxx 801-x-xxx	TEMPORARY CURB RAMP TEMPORARY ACCESSIBLE PEDESTRIAN PATH TEMPORARY PEDESTRIAN CHANNELIZER AUDIBLE INFORMATION DEVICE	
Standard Drawings: E 801-TPAR series	(proposed new)	
Item No. 3	Mr. Reilman	pg. 31
2024 Standard Specifications: 706.02 706.04	Materials Concrete Railing with Reinforced Concrete Moment Slab	
Item No. 4	Mr. Novak	pg. 35
2024 Standard Specifications: 602.03 706.03 706.04	Concrete Barrier and Concrete Glare Screen Concrete Railing Concrete Railing with Reinforced Concrete Moment Slab	
Item No. 5	Mr. Reilman	pg. 40
Recurring Special Provision: 738-B-297	WARRANTED POLYMER OVERLAY SYSTEM FOR BRIDGE DECK SURFACES AND POLYMER OVERLAY SYSTEM FOR NON-BRIDGE DECKS	
Item No. 6	Mr. White	pg. 46
Recurring Special Provision: 714-R-748	WATERPROOFING MEMBRANE FOR REINFORCED -CONCRETE BOX STRUCTURES AND THREE-SIDED STRUCTURES	
Item No. 7	Mr. Novak	pg. 55
2024 Standard Specifications: 106.05	Storage of Materials	

Item No. 8 Mr. White pg. 59

Standard Drawings:

E 619-PRWS-01

*COATING REQUIREMENTS FOR STRUCTURAL
STEEL INDEX*

E 619-PRWS-012

*PAINTING COATING REQUIREMENTS FOR
WEATHERING STEEL*

E 619-PRWS-03

*COATING REQUIREMENTS FOR EXISTING
STRUCTURAL STEEL ENCASED IN CONCRETE*

Item No. 9 Mr. Reilman pg. 66

Recurring Special Provision:

619-B-321

BRIDGE PAINTING

Item No. 10 Mr. Novak pg. 70

Recurring Special Provision:

801-T-xxx

PROTECT THE QUEUE TRUCKS

cc: Committee Members
FHWA
ICI

PROPOSAL TO STANDARDS COMMITTEE

PROBLEM(S) ENCOUNTERED: Revisions to the AASHTO LRFD Bridge Design Specifications over the years have resulted in longer required lap lengths when splicing reinforcing bars. If the lap length of the reinforcement isn't shown on the plans, Section 703.06 specifies that the bars shall be lapped 32 bar diameters. This is a shorter than the lap lengths currently required by AASHTO.

PROPOSED SOLUTION: The lap length shown in 703.06 will be increased from the current 32 bar diameters to 64 bar diameters. There are many variables that contribute to the AASHTO lap length calculations, and the proposed 64 bar diameters will envelope all scenarios and result in a lap that satisfies the current code requirements. Since lap lengths should always be shown on the contract plans, the lap required by 703.06 should not be used frequently and, therefore, will not result in excessive reinforcement on typical projects.

APPLICABLE STANDARD SPECIFICATIONS: 703.06

APPLICABLE STANDARD DRAWING: N/A (lap lengths shown on series 609-RCBA are used on empirically determined reinforcement and do not need to be updated)

APPLICABLE DESIGN MANUAL CHAPTER: IDM 405 (no changes required)

APPLICABLE SECTION OF GIFE: 5.12 (no changes required)

APPLICABLE RECURRING SPECIAL PROVISION OR PLAN DETAILS: N/A

PAY ITEMS AFFECTED: N/A

APPLICABLE SUB-COMMITTEE ENDORSEMENT: Ad hoc committee consisting of Joe Novak, Jim Reilman, Elizabeth Mouser, Jim Lesh, Stephanie Wagner, Jon Korff, and Mike Nelson

IF APPROVED AS RECURRING SPECIAL PROVISION OR PLAN DETAILS, PROPOSED BASIS FOR USE: Projects containing 703 pay items

IMPACT ANALYSIS (attach report):

Submitted By: Pete White

Title: Design Manager

Division: INDOT Bridge Engineering

E-mail: pewwhite@indot.in.gov

Date: November 15, 2023

IMPACT ANALYSIS REPORT CHECKLIST

Explain the business case as to why this item should be presented to the Standards Committee for approval. Answer the following questions with Yes, No or N/A.

Does this item appear in any other specification sections? No

Will approval of this item affect the Qualified Products List (QPL)? No

Will this proposal improve:

Construction costs? No

Construction time? No

Customer satisfaction? No

Congestion/travel time? No

Ride quality? No

Will this proposal reduce operational costs or maintenance effort? No

Will this item improve safety:

For motorists? No

For construction workers? No

Will this proposal improve quality for:

Construction procedures/processes? No

Asset preservation? Yes

Design process? Yes

Will this change provide the contractor more flexibility? No

Will this proposal provide clarification for the Contractor and field personnel? No

Can this item improve/reduce the number of potential change orders? NO

Is this proposal needed for compliance with:

Federal or State regulations? No

AASHTO or other design code? Yes

Is this item editorial? No

Provide any further information as to why this proposal should be placed on the Standards Committee meeting Agenda: The revision will bring section 703.06 in compliance with current AASHTO requirements.

REVISION TO 2024 STANDARD SPECIFICATIONS

SECTION 703 – REINFORCING BARS

703.06 Placing and Fastening

(Note: Proposed changes shown highlighted gray)

The Standard Specifications are revised as follows:

SECTION 703, BEGIN LINE 88, DELETE AND INSERT AS FOLLOWS:

All reinforcing bars shall be furnished in the full lengths shown on the plans unless splices are indicated. No other splicing will be allowed except with written permission. Unless otherwise shown on the plans, reinforcing bars shall be lapped ~~32~~⁶⁴ diameters to make a splice. Construction joints shall not be made within the limits of lapped bars. For lapped splices, reinforcing bars shall be placed in contact and rigidly clamped or wired in an approved manner. Insofar as possible, splices shall be staggered and well distributed or located at points of low tensile stress. Splices will not be allowed at points where the section does not provide a distance of at least 2 in. between the splice and the nearest adjacent bar or surface of the concrete.

AGENDIA

COMMENTS AND ACTION

703.06 Placing and Fastening

DISCUSSION:

Motion:	<u>Action:</u>
Second:	<input type="checkbox"/> Passed as Submitted
Ayes:	<input type="checkbox"/> Passed as Revised
Nays:	<input type="checkbox"/> Withdrawn
FHWA Approval:	
2024 Standard Specifications Sections: 703.06 pg. 651-652.	<input type="checkbox"/> 2026 Standard Specifications
Recurring Special Provisions or Plan Details: NONE	<input type="checkbox"/> Revise Pay Items List
Standard Drawing affected: NONE	<input type="checkbox"/> Notification to Designers if change is <u>not</u> addressed by RSP
Design Manual Chapter: IDM 405	<input type="checkbox"/> Create RSP (No. __) Effective:
GIFE Section: 5.12	<input type="checkbox"/> Revise RSP (No. __) Effective:
	<input type="checkbox"/> Standard Drawing Effective:
	<input type="checkbox"/> Create RPD (No. __) Effective:
	<input type="checkbox"/> GIFE Update
	<input type="checkbox"/> Frequency Manual Update
	<input type="checkbox"/> SiteManager Update

PROPOSAL TO STANDARDS COMMITTEE

PROBLEM(S) ENCOUNTERED: A wide range of pedestrians may be affected by a work zone, including the young, elderly, and people with disabilities. To better provide accessible temporary facilities for pedestrians and to help satisfy federal rules on pedestrian access there is a need to standardize details and create recurring special provisions for related devices and features.

PROPOSED SOLUTION: Establish a new Standard Drawing series for temporary pedestrian access routes (801-TPAR) and create recurring special provisions for [1] temporary curb ramps, [2] temporary accessible pedestrian paths, [3] temporary pedestrian channelizers, and [4] audible information devices.

APPLICABLE STANDARD SPECIFICATIONS: 801

APPLICABLE STANDARD DRAWING: Proposed new series on temporary pedestrian access routes (801-TPAR).

APPLICABLE DESIGN MANUAL CHAPTER: IDM §503-3.04(13)

APPLICABLE SECTION OF GIFE: §22

APPLICABLE RECURRING SPECIAL PROVISION OR PLAN DETAILS: N/A

PAY ITEMS AFFECTED: N/A

APPLICABLE SUB-COMMITTEE ENDORSEMENT: The proposed RSP and Standard Drawings have been reviewed by INDOT's ADA Technical Advisory Committee and industry.

IF APPROVED AS RECURRING SPECIAL PROVISION OR PLAN DETAILS, PROPOSED BASIS FOR USE: Required for all contracts with **801-11990**, **801-12641**, **801-12862**, **801-12863**, temporary curb ramp, temporary accessible pedestrian path, temporary pedestrian channelizer, or audible information device, pay items.

IMPACT ANALYSIS (attach report): Yes

Submitted By: Joe Bruno on behalf of Dave Boruff
Title: Sr. Traffic Engineer, Signals & Markings
Division: Traffic Engineering
Email: jbruno@indot.in.gov
Date: 11-27-2023

IMPACT ANALYSIS REPORT CHECKLIST

Explain the business case as to why this item should be presented to the Standards Committee for approval. Answer the following questions with Yes, No or N/A.

Does this item appear in any other specification sections? No

Will approval of this item affect the Qualified Products List (QPL)? No

Will this proposal improve:

Construction costs? No

Construction time? Yes

Customer satisfaction? Yes

Congestion/travel time? No

Ride quality? No

Will this proposal reduce operational costs or maintenance effort? No

Will this item improve safety:

For motorists? No

For pedestrians? Yes

For construction workers? Yes

Will this proposal improve quality for:

Construction procedures/processes? Yes

Asset preservation? No

Design process? Yes

Will this change provide the contractor more flexibility? No

Will this proposal provide clarification for the Contractor and field personnel? Yes

Can this item improve/reduce the number of potential change orders? Yes

Is this proposal needed for compliance with:

Federal or State regulations? Yes

AASHTO or other design code? Yes, PROWAG

Is this item editorial? No

Provide any further information as to why this proposal should be placed on the Standards Committee meeting Agenda: On 8/8/2023, the U.S. Access Board issued the final rule for the Public Right-of-way Accessibility Guidelines and this proposal will further compliance with the requirements for temporary pedestrian facilities.

REVISION TO SPECIAL PROVISIONS AND STANDARD DRAWINGS

- 801-x-xxx TEMPORARY CURB RAMP (proposed new)
- 801-x-xxx TEMPORARY ACCESSIBLE PEDESTRIAN PATH (proposed new)
- 801-x-xxx TEMPORARY PEDESTRIAN CHANNELIZER (proposed new)
- 801-x-xxx AUDIBLE INFORMATION DEVICE (proposed new)

801-x-xxx TEMPORARY CURB RAMP

(Adopted xx-xx-xx)

Description

This work shall consist of installing temporary curb ramps for temporary pedestrian access at various intersections in accordance with 105.03.

Materials

Materials shall be in accordance with 604.02 or from the Department's QPL of ADA Compliant Work Zone Devices.

Construction Requirements

The Contractor shall place temporary curb ramps to provide ADA compliant temporary access for pedestrians in accordance with 107.08 and as shown on the plans.

The temporary curb ramp shall be a minimum of 48 in. wide and have a slip resistant surface. The ramp shall not have greater than an 8.33% running slope or 2.00% cross slope.

For curb heights greater than 4 in, the temporary curb ramp shall have edge protection. For curb heights less than or equal to 4 in. either the sides shall be flared, or edge protection shall be provided. Edge protection shall be continuous and at least 8 in. in height. Rails or other barriers used for edge protection shall protrude less than 4 in. into the curb ramp.

Handrails are required for curb ramps with a rise greater than 6.0 in. The handrail shall be at least 34 in. but no more than 38 in. above the surface of the ramp and any lower handrail shall be no more than 28 in. above the ramp surface.

The temporary curb ramp shall be placed either perpendicular or parallel to the curb. If the ramp is placed parallel to curb a minimum of a 48 in. by 48 in. turning space shall be provided at each required turn location. The turning space shall have a cross slope and running slope of 2.00% or less.

Temporary curb ramp shall be accessed from an ADA compliant landing area.

The temporary curb ramp shall be kept free of any obstructions or trip hazards including debris, mud, construction equipment, and stored materials.

For temporary curb ramps not constructed in accordance with 604.02 the Contractor shall submit the manufacturer's technical data, specifications and installation instructions for the model selected from the QPL to the Engineer for approval.

The final layout of the temporary curb ramp at each location shall

REVISION TO SPECIAL PROVISIONS AND STANDARD DRAWINGS

- 801-x-xxx TEMPORARY CURB RAMP (proposed new)
- 801-x-xxx TEMPORARY ACCESSIBLE PEDESTRIAN PATH (proposed new)
- 801-x-xxx TEMPORARY PEDESTRIAN CHANNELIZER (proposed new)
- 801-x-xxx AUDIBLE INFORMATION DEVICE (proposed new)

be as approved by the Engineer prior to closing the existing sidewalk.

Method of Measurement

Temporary curb ramp will be measured by the number of units installed, maintained, and removed.

Basis of Payment

The accepted quantity of temporary curb ramps will be paid for at the contract unit price per each.

Payment will be made under:

Pay Item	Pay Unit Symbol
Temporary Curb Ramp	EACH

The cost of all labor, materials, equipment, and all necessary incidentals required to place the temporary curb ramps during construction operations and removal of the temporary curb ramps after construction is complete shall be included in the cost of the temporary curb ramp.

REVISION TO SPECIAL PROVISIONS AND STANDARD DRAWINGS

- 801-x-xxx TEMPORARY CURB RAMP (proposed new)
- 801-x-xxx TEMPORARY ACCESSIBLE PEDESTRIAN PATH (proposed new)
- 801-x-xxx TEMPORARY PEDESTRIAN CHANNELIZER (proposed new)
- 801-x-xxx AUDIBLE INFORMATION DEVICE (proposed new)

801-x-xxx TEMPORARY ACCESSIBLE PEDESTRIAN PATH

(Adopted xx-xx-xx)

Description

This work shall consist of installing temporary surfaces for temporary pedestrian access at in accordance with 105.03 and as shown on the plans.

Materials

Materials shall be in accordance with 604.02 or selected from the Department's QPL of ADA Compliant Work Zone Devices and as follows.

The temporary surface shall be a minimum of 48 in. wide. The temporary surface shall not be made of plywood. The temporary surface shall have a firm and stable slip resistant surface.

Construction Requirements

The Contractor shall place temporary surfaces to provide ADA compliant temporary access for pedestrians in accordance with 107.08, 604, 801 and as shown on the plans.

Prior to placement of the temporary surface, the existing ground shall be cleared of any removable debris to provide a level surface. The maximum cross slope shall be 2.00%. The existing ground shall be cleared or excavated of natural vegetation as needed for temporary surface construction.

The temporary accessible pedestrian path shall be kept free of any obstructions or trip hazards including debris, mud, construction equipment, and stored materials.

If the temporary surface is less than 60 in. wide a 60 in. by 60 in. passing space shall be provided every 200 ft.

The final layout of the temporary pedestrian access path at each location shall be as approved by the Engineer prior to closing any existing sidewalk.

Method of Measurement

Temporary surfaces for temporary pedestrian access will be measured by the square yard.

Basis of Payment

The accepted quantity of temporary surfaces for temporary pedestrian access will be paid for at the contract unit price per square yard.

Payment will be made under:

Pay Item	Pay Unit Symbol
Temporary Accessible Pedestrian Path	SYS

REVISION TO SPECIAL PROVISIONS AND STANDARD DRAWINGS

- 801-x-xxx TEMPORARY CURB RAMP (proposed new)
- 801-x-xxx TEMPORARY ACCESSIBLE PEDESTRIAN PATH (proposed new)
- 801-x-xxx TEMPORARY PEDESTRIAN CHANNELIZER (proposed new)
- 801-x-xxx AUDIBLE INFORMATION DEVICE (proposed new)

The cost of all labor, materials, equipment, railing, handrail, excavation or removal of existing vegetation, in-kind replacement of existing vegetation and all necessary incidentals required to place the temporary surfaces during construction operations and removal of the temporary surfaces after construction is complete shall be included in the cost of the pay item.

AGENDA

REVISION TO SPECIAL PROVISIONS AND STANDARD DRAWINGS

- 801-x-xxx TEMPORARY CURB RAMP (proposed new)
- 801-x-xxx TEMPORARY ACCESSIBLE PEDESTRIAN PATH (proposed new)
- 801-x-xxx TEMPORARY PEDESTRIAN CHANNELIZER (proposed new)
- 801-x-xxx AUDIBLE INFORMATION DEVICE (proposed new)

801-x-xxx TEMPORARY PEDESTRIAN CHANNELIZER

(Adopted xx-xx-xx)

Description

This work shall consist of installing temporary traffic barriers used as pedestrian channelizers to provide a barrier between pedestrians and construction activities at various intersections in accordance with 105.03 and as shown on the plans.

Materials

Materials shall be in accordance with 801.02 and selected from the INDOT Qualified Products List for ADA Compliant Work Zone Devices.

Construction Requirements

The Contractor shall place the temporary pedestrian channelizer in accordance with 801.10, as shown on the plans.

The temporary pedestrian channelizer shall have a minimum height of 32 in. The temporary pedestrian channelizers shall interlock such that gaps do not allow pedestrians to stray from the channelized path.

The temporary pedestrian channelizers shall have continuous hand-trailing edging on sides facing pedestrian traffic with a minimum height of 32 in. and a maximum height of 38 in.

The temporary pedestrian channelizer shall have a continuous detection plate on sides facing pedestrian traffic no greater than 2 in. above the ground. The detection plate shall have a minimum height of 8 in.

The top and bottom of the surfaces of the temporary pedestrian channelizer, or the hand-trailing edging and detection plate shall have strips of alternating orange and white reflective sheeting oriented vertically or at a 45° angle.

Temporary pedestrian channelizers shall not block water drainage from the walkway. A gap height or opening from the walkway surface up to 2 in. maximum height is allowed for drainage purposes.

Temporary pedestrian channelizers shall be free of sharp or rough edges, and fasteners shall be rounded to prevent harm to hand, arms, or clothing of pedestrians.

Ballast for the temporary pedestrian channelizers shall be located behind the device away from the pedestrian.

The final layout of the temporary pedestrian channelizer at each location shall be as approved by the Engineer the prior to closing the existing sidewalk.

Method of Measurement

REVISION TO SPECIAL PROVISIONS AND STANDARD DRAWINGS

- 801-x-xxx TEMPORARY CURB RAMP (proposed new)
- 801-x-xxx TEMPORARY ACCESSIBLE PEDESTRIAN PATH (proposed new)
- 801-x-xxx TEMPORARY PEDESTRIAN CHANNELIZER (proposed new)
- 801-x-xxx AUDIBLE INFORMATION DEVICE (proposed new)

Temporary pedestrian channelizers will be measured by the linear foot, complete and in place.

Basis of Payment

The accepted quantity of temporary pedestrian channelizers will be paid for at the contract unit price per linear foot.

Payment will be made under:

Pay Item	Pay Unit Symbol
Temporary Pedestrian Channelizer.....	LFT

The cost of all labor, materials, equipment, and all necessary incidentals required to place the temporary pedestrian channelizers during construction operations and removal of the channelizers after construction is complete shall be included in the cost of the temporary pedestrian channelizer.

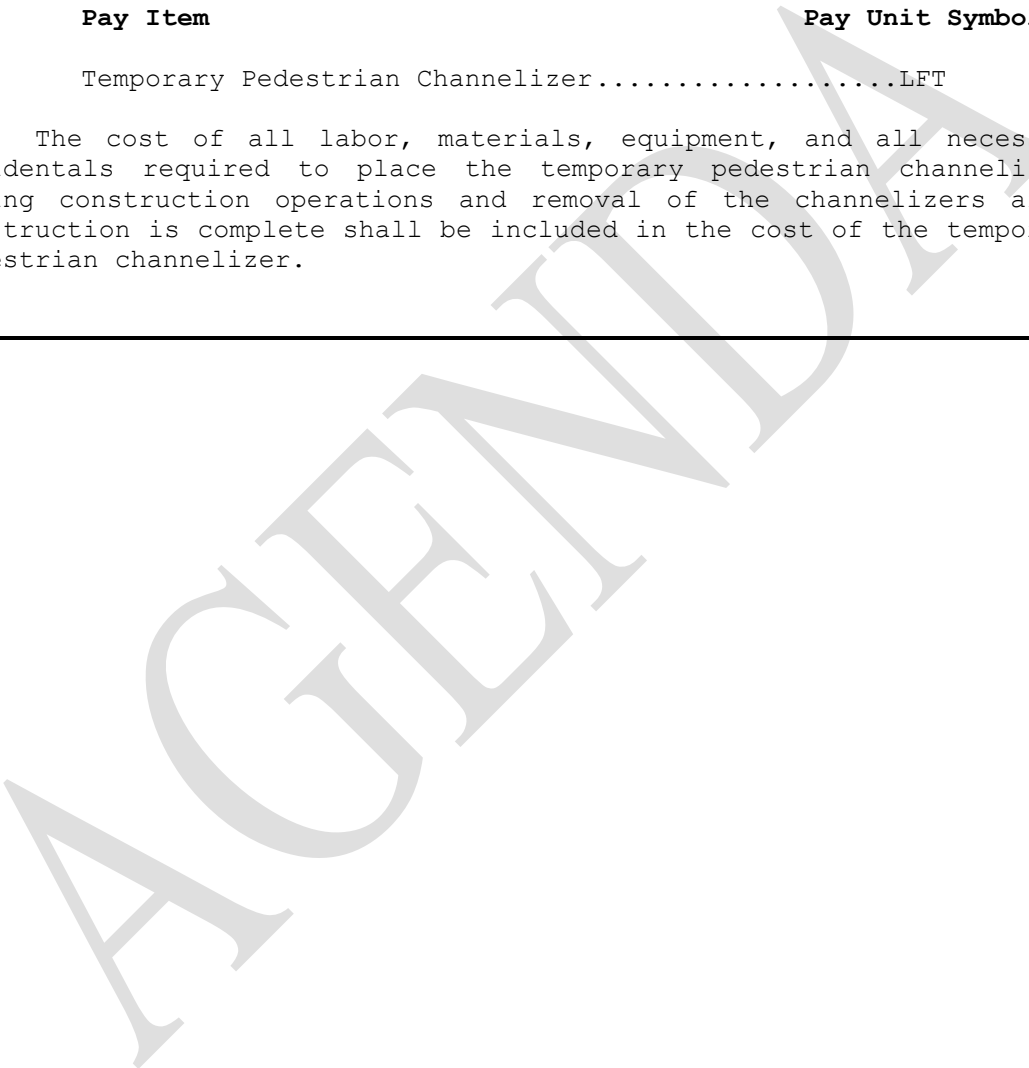

REVISION TO SPECIAL PROVISIONS AND STANDARD DRAWINGS

- 801-x-xxx TEMPORARY CURB RAMP (proposed new)
- 801-x-xxx TEMPORARY ACCESSIBLE PEDESTRIAN PATH (proposed new)
- 801-x-xxx TEMPORARY PEDESTRIAN CHANNELIZER (proposed new)
- 801-x-xxx AUDIBLE INFORMATION DEVICE (proposed new)

801-x-xxx AUDIBLE INFORMATION DEVICE

(Adopted xx-xx-xx)

Description

This work shall consist of installing audible information in accordance with 105.03 and as shown on the plans. The device aids movement of visually disabled pedestrians at intersections and mid-block crosswalks by providing notification of sidewalk or crosswalks closures.

Materials

Materials shall be in accordance with 801.02 and selected from the Department's QPL of ADA Compliant Work Zone Devices.

Construction Requirements

The Contractor shall place the audible information device in accordance with 801.10 or as shown on the plans.

The device shall emit a speech message to inform pedestrians of the sidewalk or crosswalk closure, guide them to the temporary crossing location and guide them along the pedestrian detour. The device shall be capable of having a 60 second message duration and shall be equipped with a built-in microphone for programming the message. The device shall have a built-in speaker for broadcasting.

The device shall be activated either by built-in sensors that detect pedestrians at a minimum range of 15 ft or by a pushbutton with a locator tone. The device shall be battery powered.

The device shall be mountable on channelizing devices, pedestrian barriers, or on an independent support post.

The Audible Information Device shall be placed at or near the closure, at locations on the pedestrian detour where a turn is required, and at other locations as shown on the plans. The audible information devices shall not reduce the effective sidewalk or pedestrian pathway width to less than 4 ft.

The final location of the audible information device at each location shall be approved by the Engineer prior to closing the existing crosswalk or sidewalk.

Method of Measurement

The audible information devices will be measured by the number of units installed.

Basis of Payment

The accepted quantity of audible information device will be paid for at the contract unit price per each.

Payment will be made under:

REVISION TO SPECIAL PROVISIONS AND STANDARD DRAWINGS

- 801-x-xxx TEMPORARY CURB RAMP (proposed new)
- 801-x-xxx TEMPORARY ACCESSIBLE PEDESTRIAN PATH (proposed new)
- 801-x-xxx TEMPORARY PEDESTRIAN CHANNELIZER (proposed new)
- 801-x-xxx AUDIBLE INFORMATION DEVICE (proposed new)

Pay Item	Pay Unit Symbol
Audible Information Device.....	EACH

The cost of all labor, materials, equipment and all necessary incidentals required to place the audible information device during construction operations and removal of the device after construction is complete shall be included in the cost of the audible information device.



REVISION TO SPECIAL PROVISIONS AND STANDARD DRAWINGS

E 801-TPAR-01 INDEX AND GENERAL NOTES (proposed new)

INDEX	
SHEET NO.	SUBJECT - TEMPORARY PEDESTRIAN ACCESS ROUTES
1	Index and General Notes
2	Pedestrian Detour Corner Closure
3	Pedestrian Detour Crosswalk Closure
4	Pedestrian Detour Full Block Closure
5	Pedestrian Detour Multi-Block Closure
6	Pedestrian Detour Midblock Closure
7	Pedestrian Detour Midblock Closure with Temporary Crossing
8	Pedestrian Diversion, Streetside
9	Pedestrian Diversion, Streetside at Intersection
10	Pedestrian Diversion, Right-of-way Side
11	Temporary Curb Ramps
12	Temporary Pedestrian Channelizers

GENERAL NOTES:

1. Signs, railings, or other objects may protrude a max. of 4 in. into the walkway clear space when located 27 in. minimum above the walkway surface.
2. Any construction signs placed in the sidewalk shall include supports with detectable edging in accordance with Part 6 of the MUTCD.
3. Audible information devices shall be a minimum of 15 ft apart.
4. Pedestrian traffic signal displays controlling closed crosswalks shall be covered or deactivated.
5. Type A flashing warning lights may be omitted on pedestrian channelizers that support signs and closed sidewalks during daytime only closures.
6. Construction signs shall not reduce the available width of a temporary pedestrian access route to less than 4 ft.

INDIANA DEPARTMENT OF TRANSPORTATION	
INDEX AND GENERAL NOTES	
SEPTEMBER 2024	
STANDARD DRAWING NO.	E 801-TPAR-01
DESIGN STANDARDS ENGINEER	DATE
CHIEF ENGINEER	DATE

REVISION TO SPECIAL PROVISIONS AND STANDARD DRAWINGS

E 801-TPAR-02 PEDESTRIAN DETOUR CORNER CLOSURE (proposed new)

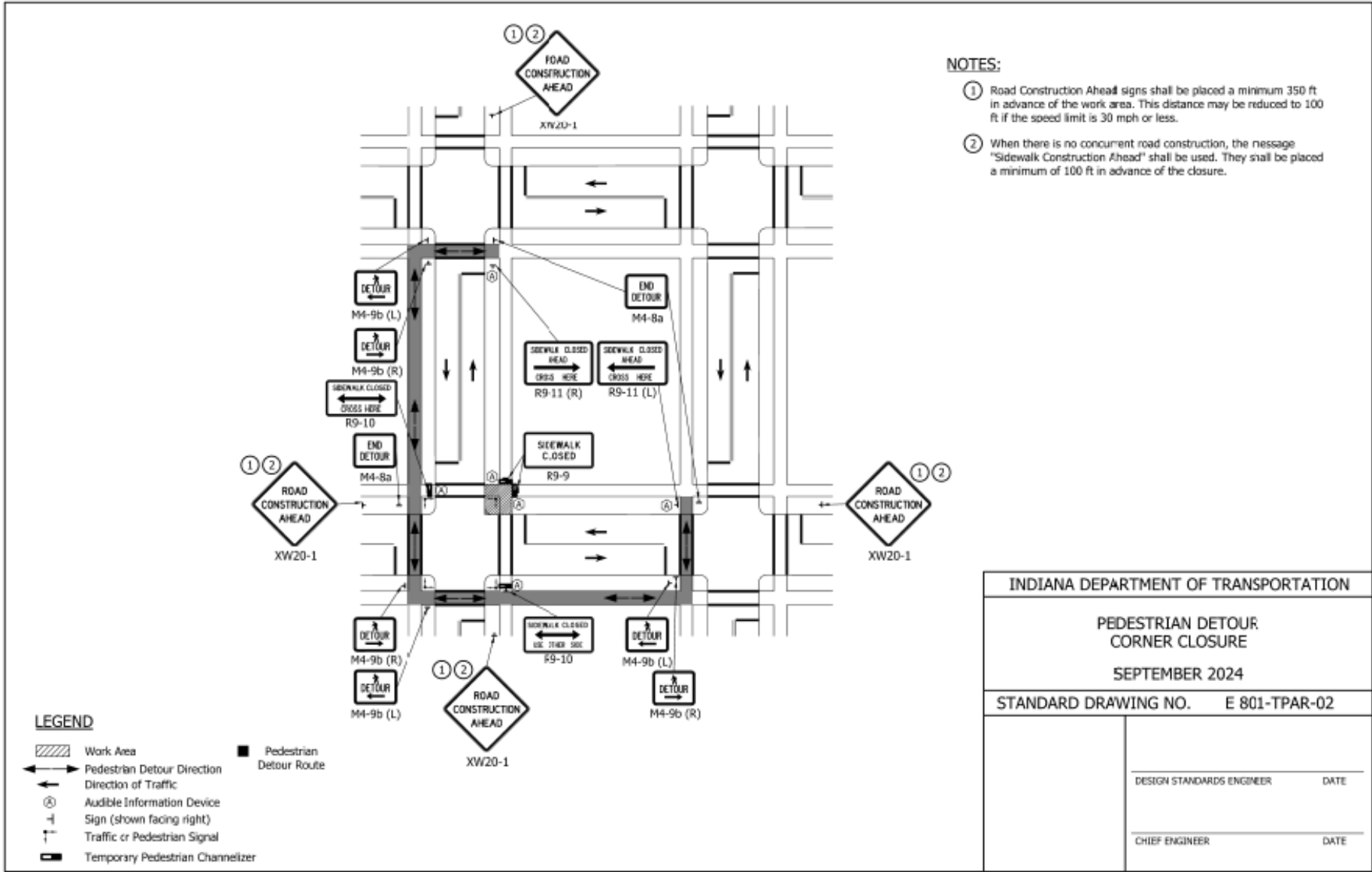

- NOTES:**
- ① Road Construction Ahead signs shall be placed a minimum 350 ft in advance of the work area. This distance may be reduced to 100 ft if the speed limit is 30 mph or less.
 - ② When there is no concurrent road construction, the message "Sidewalk Construction Ahead" shall be used. They shall be placed a minimum of 100 ft in advance of the closure.

INDIANA DEPARTMENT OF TRANSPORTATION	
PEDESTRIAN DETOUR CORNER CLOSURE	
SEPTEMBER 2024	
STANDARD DRAWING NO. E 801-TPAR-02	
	DESIGN STANDARDS ENGINEER DATE
	CHIEF ENGINEER DATE

REVISION TO SPECIAL PROVISIONS AND STANDARD DRAWINGS

E 801-TPAR-03 PEDESTRIAN DETOUR CROSSWALK CLOSURE (proposed new)

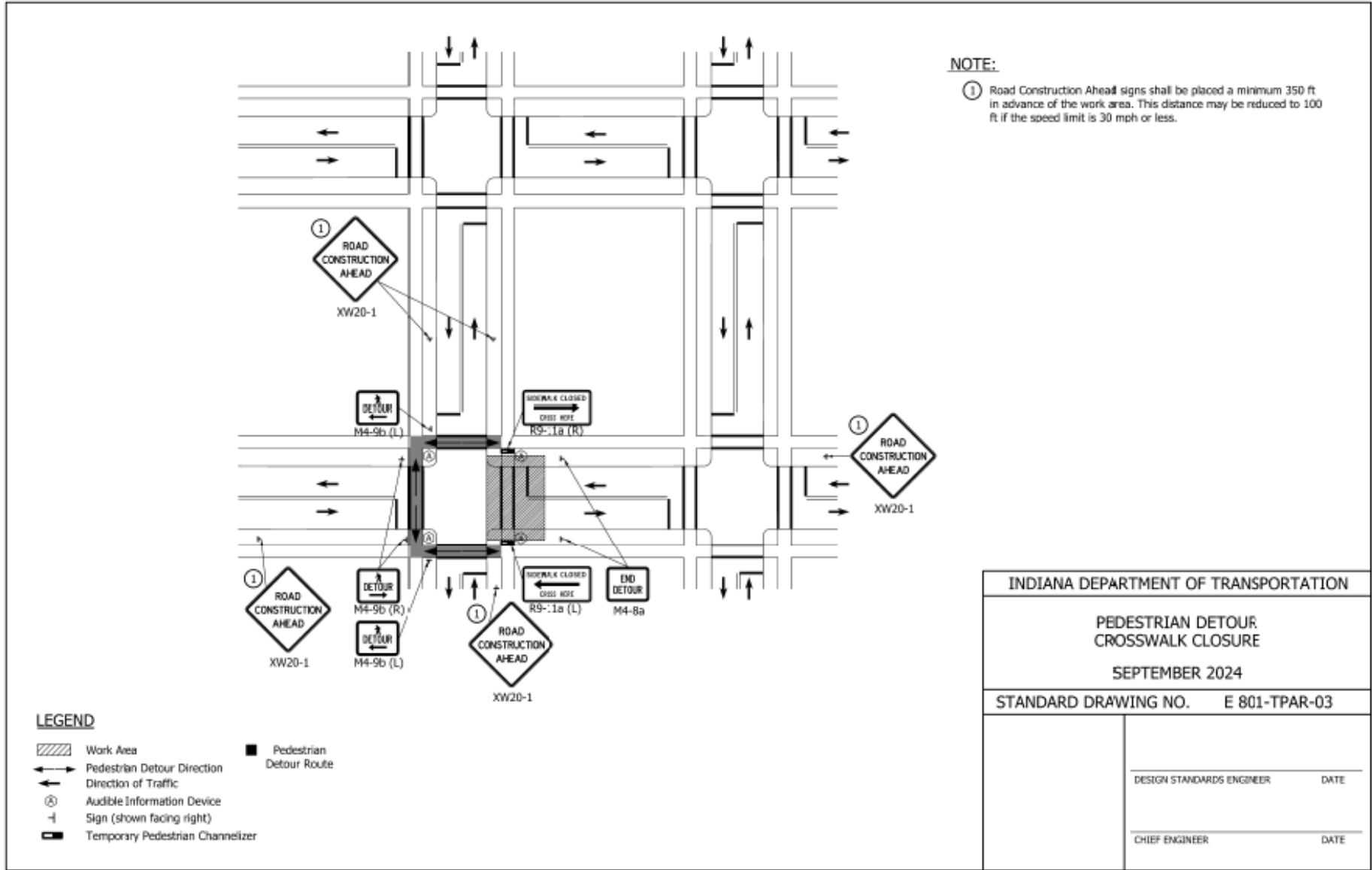

REVISION TO SPECIAL PROVISIONS AND STANDARD DRAWINGS

E 801-TPAR-04 PEDESTRIAN DETOUR FULL BLOCK CLOSURE (proposed new)

NOTES:

- ① Road Construction Ahead signs shall be placed a minimum 350 ft in advance of the work area. This distance may be reduced to 100 ft if the speed limit is 30 mph or less.
- ② When there is no concurrent road construction, the message "Sidewalk Construction Ahead" shall be used. They shall be placed a minimum of 100 ft in advance of the closure.
- 3. The Contractor shall coordinate any on-street parking restrictions with the local public agency.

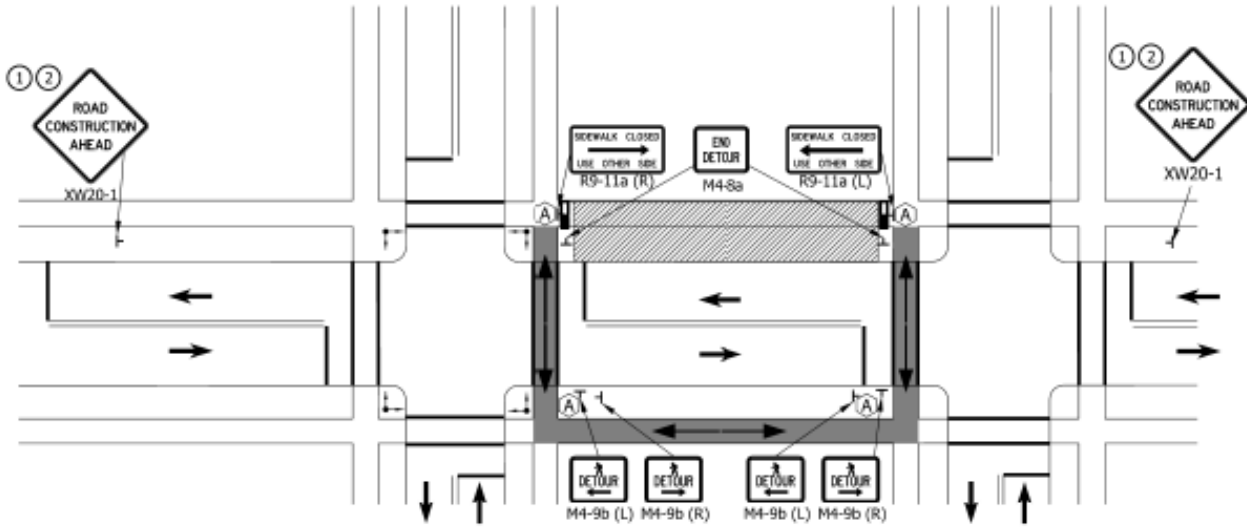

LEGEND

- Work Area
- Pedestrian Detour Direction
- Direction of Traffic
- Audible Information Device
- Sign (shown facing right)
- Traffic or Pedestrian Signal
- Temporary Pedestrian Channelizer
- Pedestrian Detour Route

INDIANA DEPARTMENT OF TRANSPORTATION	
PEDESTRIAN DETOUR FULL BLOCK CLOSURE	
SEPTEMBER 2024	
STANDARD DRAWING NO.	E 801-TPAR-04
DESIGN STANDARDS ENGINEER	DATE
CHIEF ENGINEER	DATE

REVISION TO SPECIAL PROVISIONS AND STANDARD DRAWINGS

E 801-TPAR-05 PEDESTRIAN DETOUR MUL TI-BLOCK CLOSURE (proposed new)

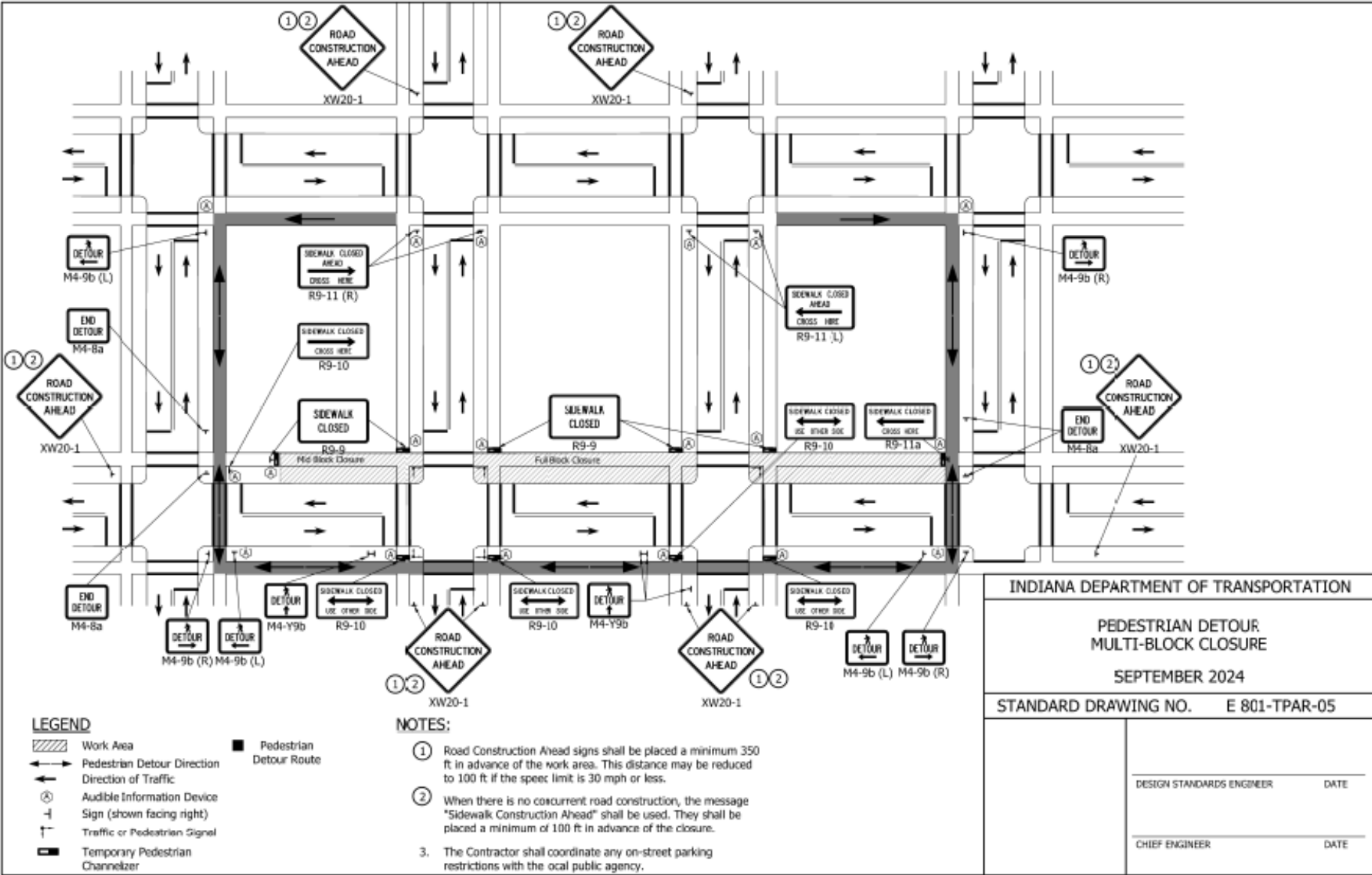

REVISION TO SPECIAL PROVISIONS AND STANDARD DRAWINGS

E 801-TPAR-06 PEDESTRIAN DETOUR MIDBLOCK CLOSURE (proposed new)

NOTES:

- ① Road Construction Ahead signs shall be placed a minimum 350 ft in advance of the work area. This distance may be reduced to 100 ft if the speed limit is 30 mph or less.
- ② When there is no concurrent road construction, the message "Sidewalk Construction Ahead" shall be used. They shall be placed a minimum of 100 ft in advance of the closure.
- 3. The Contractor shall coordinate any on-street parking restrictions with the local public agency.

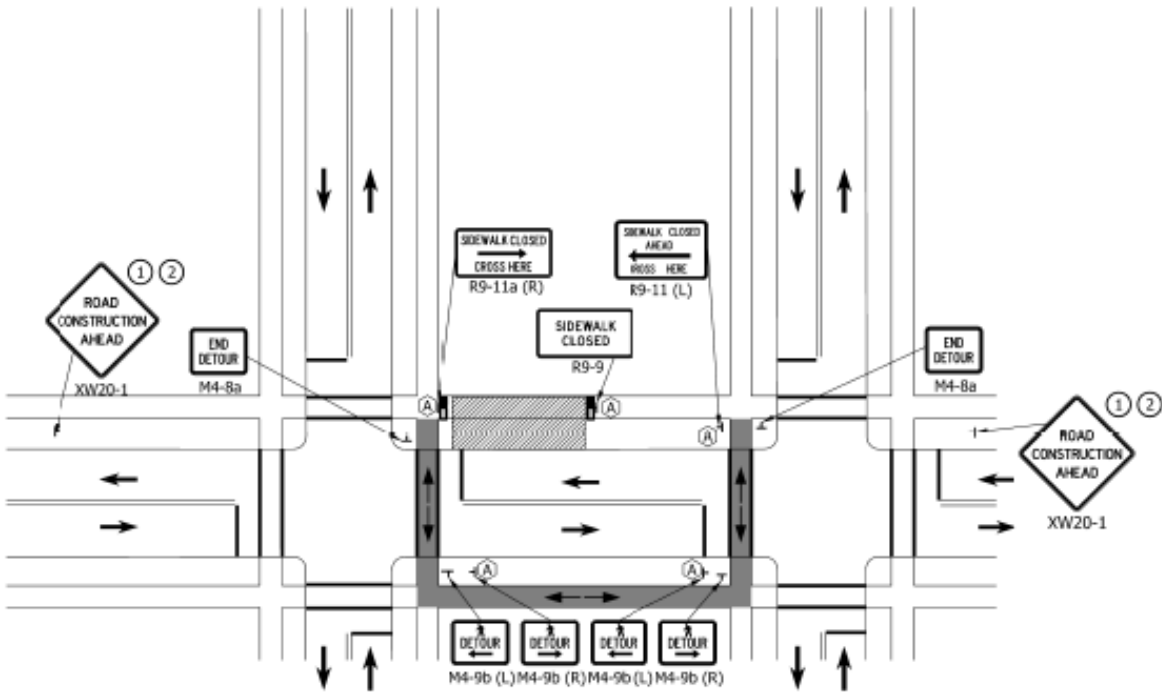

LEGEND

- Work Area
- Pedestrian Detour Direction
- Direction of Traffic
- Audible Information Device
- Sign (shown facing right)
- Traffic or Pedestrian Signal
- Temporary Pedestrian Channelizer
- Pedestrian Detour Route

INDIANA DEPARTMENT OF TRANSPORTATION	
PEDESTRIAN DETOUR MIDBLOCK CLOSURE	
SEPTEMBER 2024	
STANDARD DRAWING NO. E 801-TPAR-06	
	DESIGN STANDARDS ENGINEER DATE
	CHIEF ENGINEER DATE

REVISION TO SPECIAL PROVISIONS AND STANDARD DRAWINGS

E 801-TPAR-07 PEDESTRIAN DETOUR TEMPORARY MIDBLOCK CLOSURE WITH TEMPORARY CROSSING (proposed new)

NOTES:

- ① Road Construction Ahead and Crosswalk Ahead signs shall be placed a minimum 500 ft and 350 ft, respectively, in advance of the work area. This distance may be reduced to 200 ft and 100 ft, respectively, if the speed limit is 30 mph or less.
- ② When there is no concurrent road construction, the message "Sidewalk Construction Ahead" shall be used. They shall be placed a minimum of 100 ft in advance of the closure.
- ③ White temporary crosswalk lines shall be a minimum of 6 (in.) in width and written approval from the District Traffic Engineer is required prior to placing the crosswalk lines and W11-2 and W16-7P sign assemblies.
4. The Contractor shall coordinate any on-street parking restrictions with the local public agency.
5. A temporary crossing shall not be used if the AADT is > 12,000 and the location of a temporary crossing on a roadway where the AADT is ≤ 12,000 shall be approved by the Engineer.

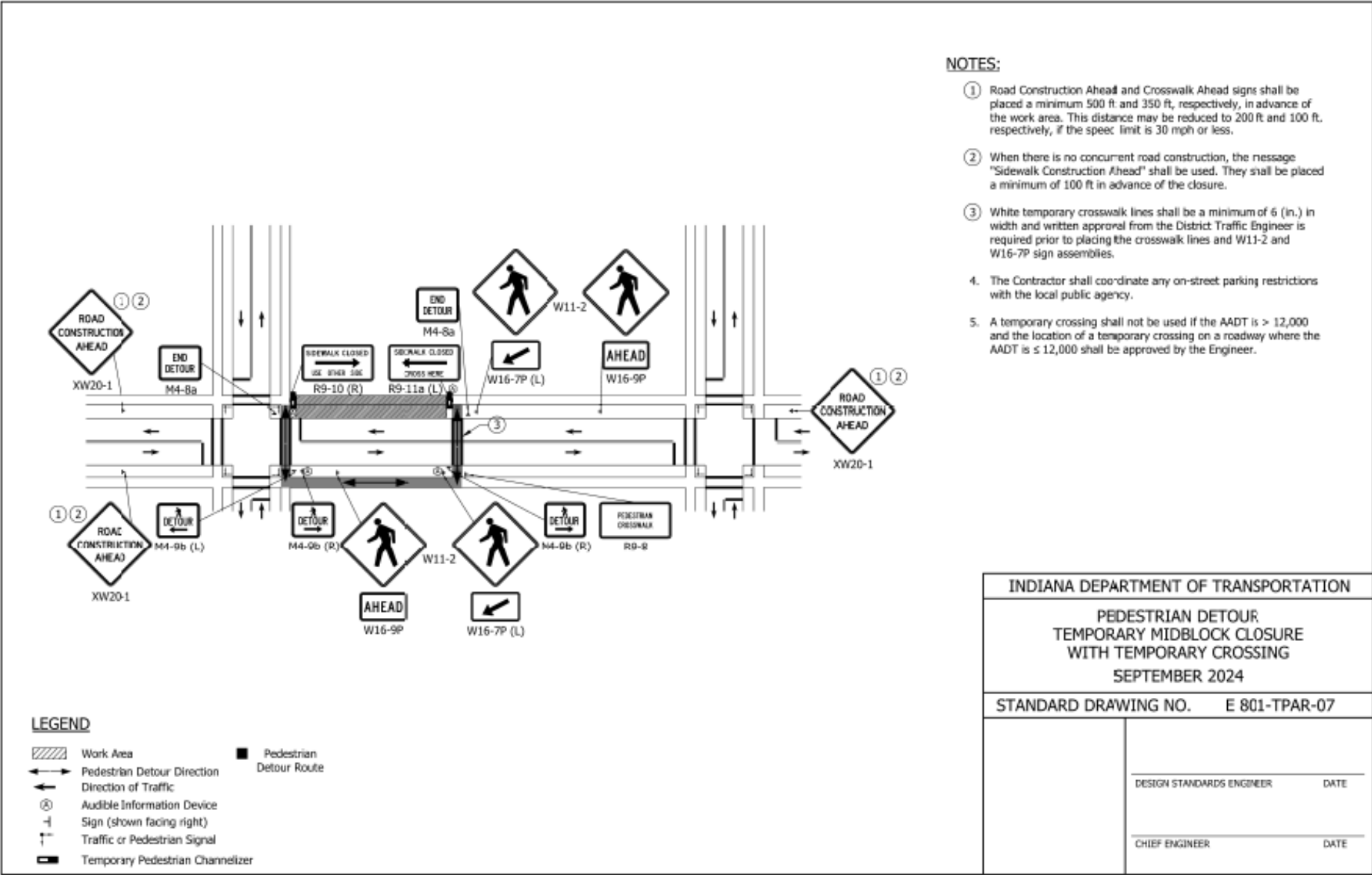

REVISION TO SPECIAL PROVISIONS AND STANDARD DRAWINGS

E 801-TPAR-08 PEDESTRIAN DIVERSION, STREETSIDE (proposed new)

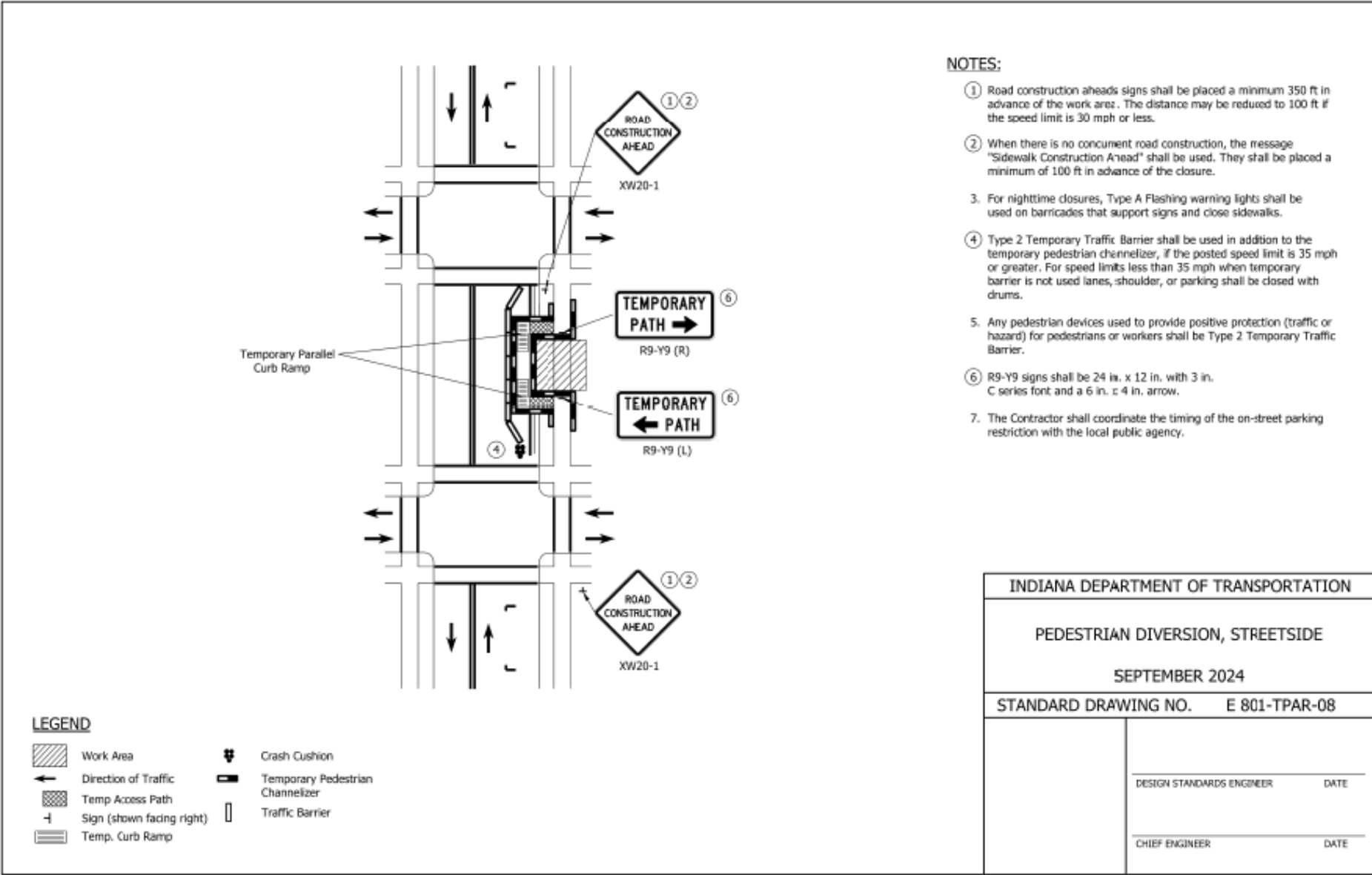

INDIANA DEPARTMENT OF TRANSPORTATION	
PEDESTRIAN DIVERSION, STREETSIDE	
SEPTEMBER 2024	
STANDARD DRAWING NO.	E 801-TPAR-08
DESIGN STANDARDS ENGINEER	DATE
CHIEF ENGINEER	DATE

REVISION TO SPECIAL PROVISIONS AND STANDARD DRAWINGS

E 801-TPAR-09 PEDESTRIAN DIVERSION, STREETSIDE AT INTERSECTION (proposed new)

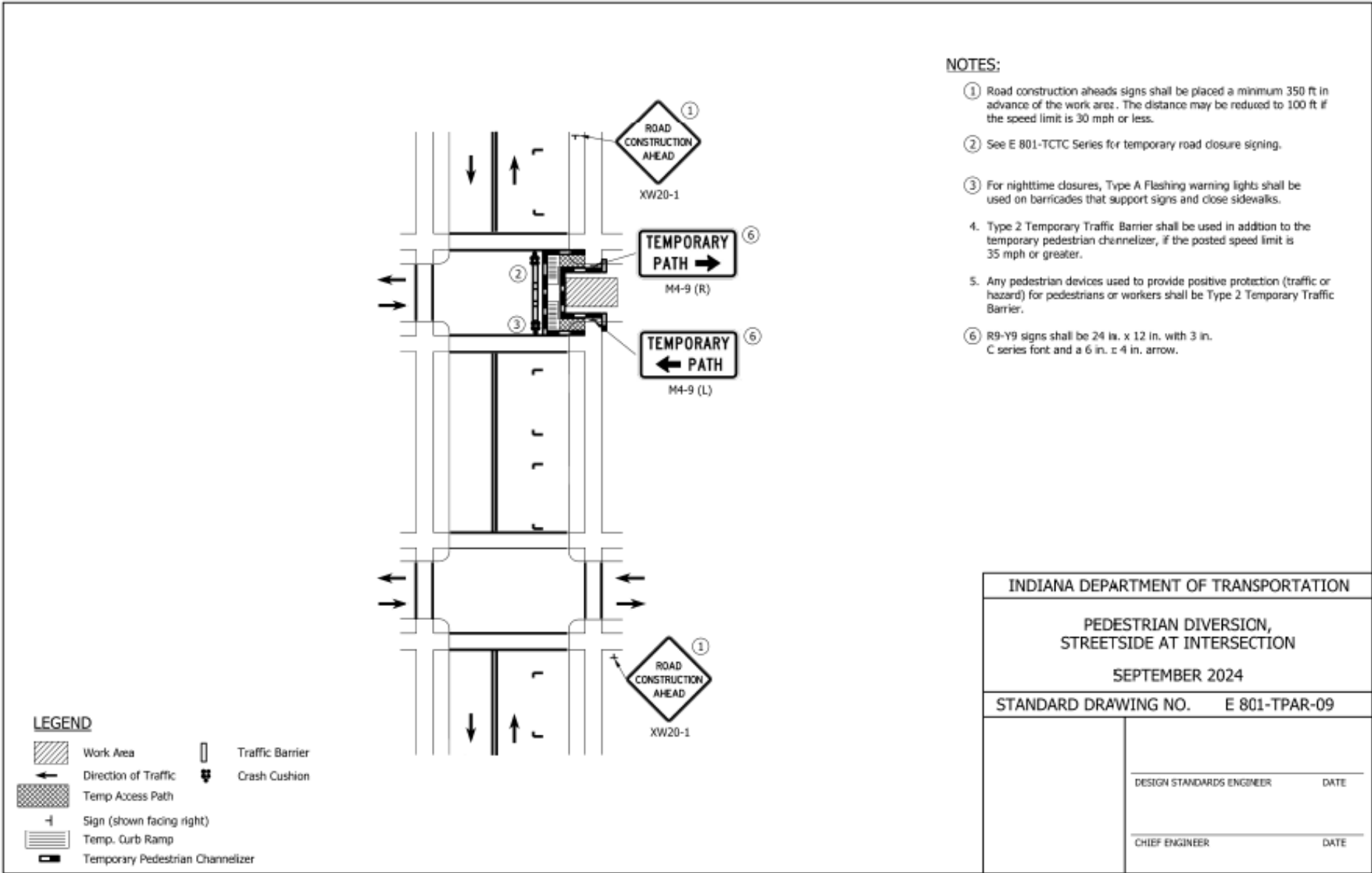

INDIANA DEPARTMENT OF TRANSPORTATION	
PEDESTRIAN DIVERSION, STREETSIDE AT INTERSECTION	
SEPTEMBER 2024	
STANDARD DRAWING NO. E 801-TPAR-09	
	_____ DESIGN STANDARDS ENGINEER DATE
	_____ CHIEF ENGINEER DATE

REVISION TO SPECIAL PROVISIONS AND STANDARD DRAWINGS

E 801-TPAR-10 PEDESTRIAN DIVERSION, RIGHT-OF-WAY SIDE (proposed new)

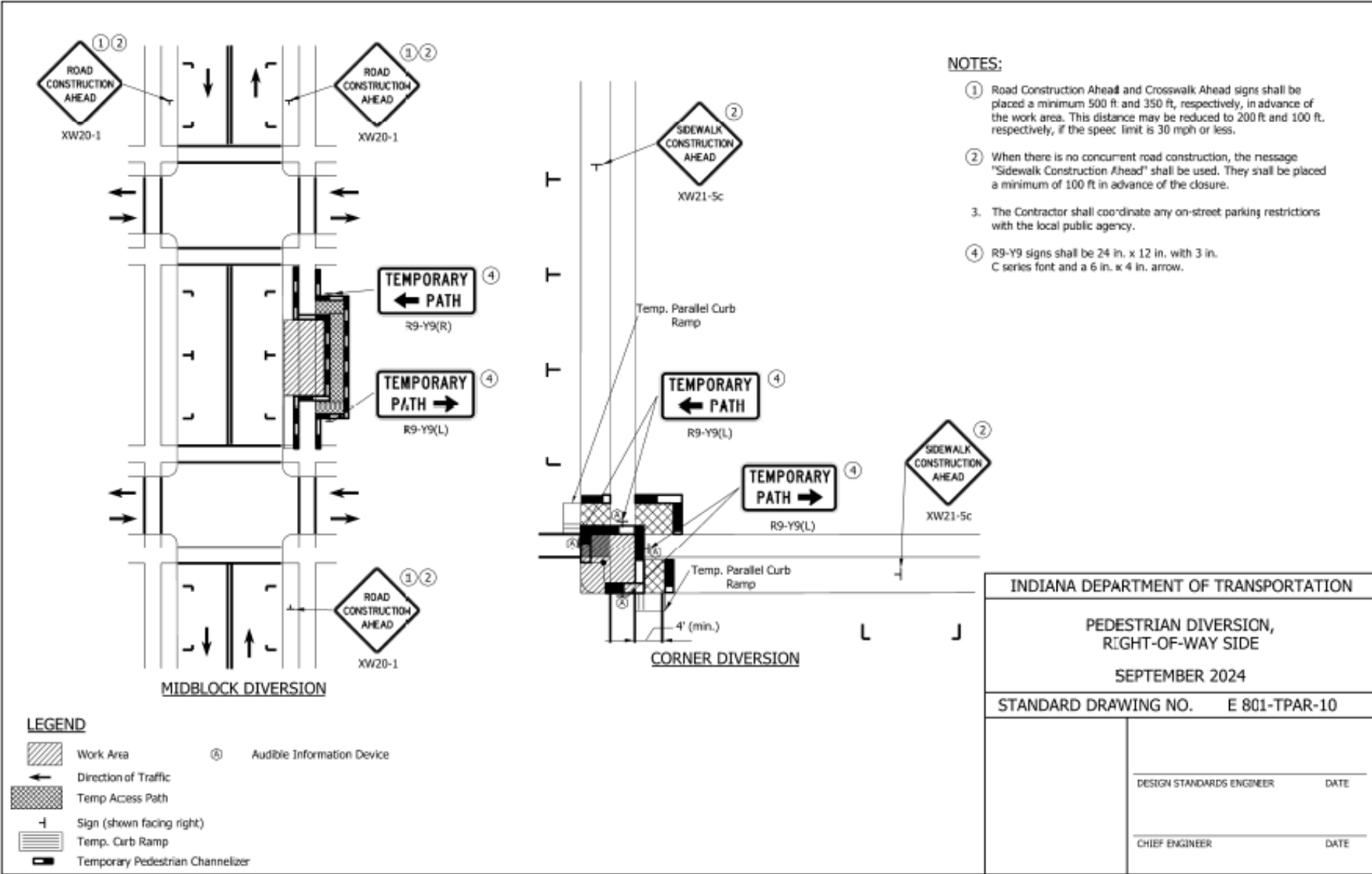

REVISION TO SPECIAL PROVISIONS AND STANDARD DRAWINGS
 E 801-TPAR-11 TEMPORARY CURB RAMPS (proposed new)

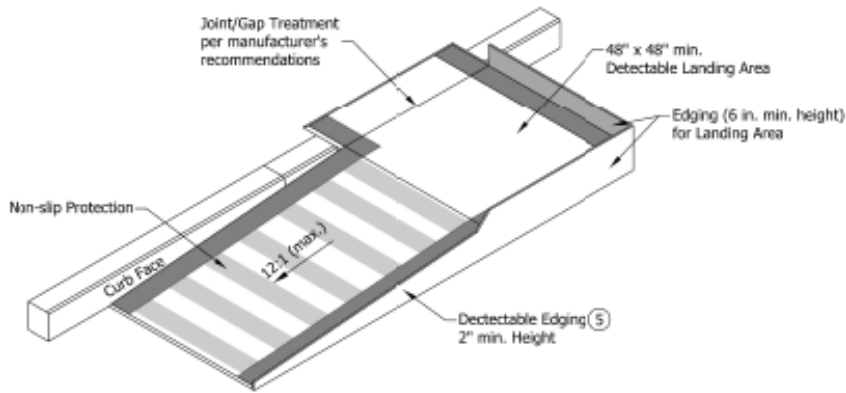

Temporary Curb Ramp - Parallel to Curb

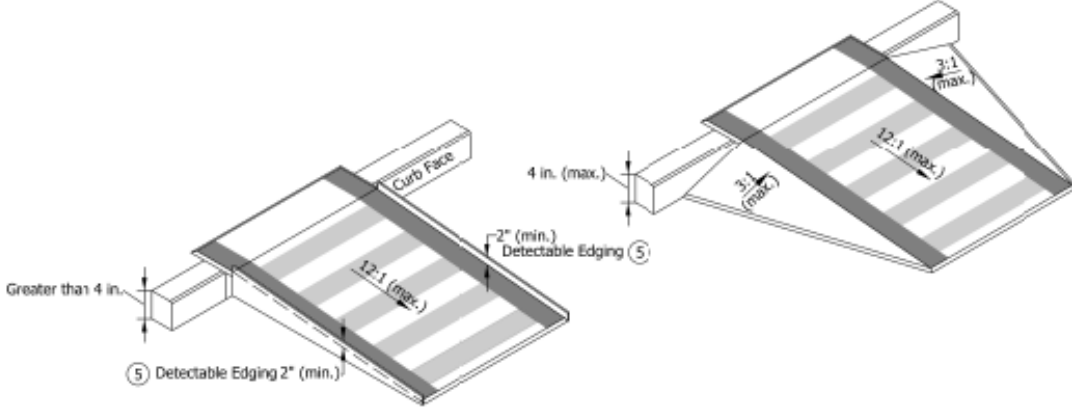

Temporary Curb Ramp - Perpendicular to Curb

NOTES:

1. Water flow in the gutter system shall be maintained.
2. Lateral joints or gaps between surfaces shall be less than 0.5 in. width.
3. Changes in level between surface heights shall not exceed 0.5 in. Lateral edges shall be vertical up to 0.25 in. high, and beveled at 2:1 between 0.25 in. and 0.5 in. in height.
4. Handrail shall be provided along a landing area and ramp where the elevation difference between the sidewalk and the street is greater than 6.0 in.
- ⑤ A 2.0 in. detectable edge shall be provided along the entire length of the ramp where the elevation difference between the sidewalk and the street is greater than 4.0 in.
6. The rise of a single temporary curb ramp shall be no more than 30 in. If more than one temporary curb ramp is needed at a location due to the change in elevation, a minimum 5 ft landing area shall be used between curb ramps. The landing area shall have a slope of less than 2.00%.
7. The table below is for common curb heights, the curb ramp length for other curb heights shall be based on having a maximum slope of 12:1.

Curb Height (in.)	Minimum Temporary Curb Ramp Length (ft)
3	3
4	4
5	5
6	6

INDIANA DEPARTMENT OF TRANSPORTATION

TEMPORARY CURB RAMPS

SEPTEMBER 2024

STANDARD DRAWING NO. **E 801-TPAR-11**

DESIGN STANDARDS ENGINEER	DATE
CHIEF ENGINEER	DATE

REVISION TO SPECIAL PROVISIONS AND STANDARD DRAWINGS

E 801-TPAR-12 TEMPORARY PEDESTRIAN CHANNELIZERS (proposed new)

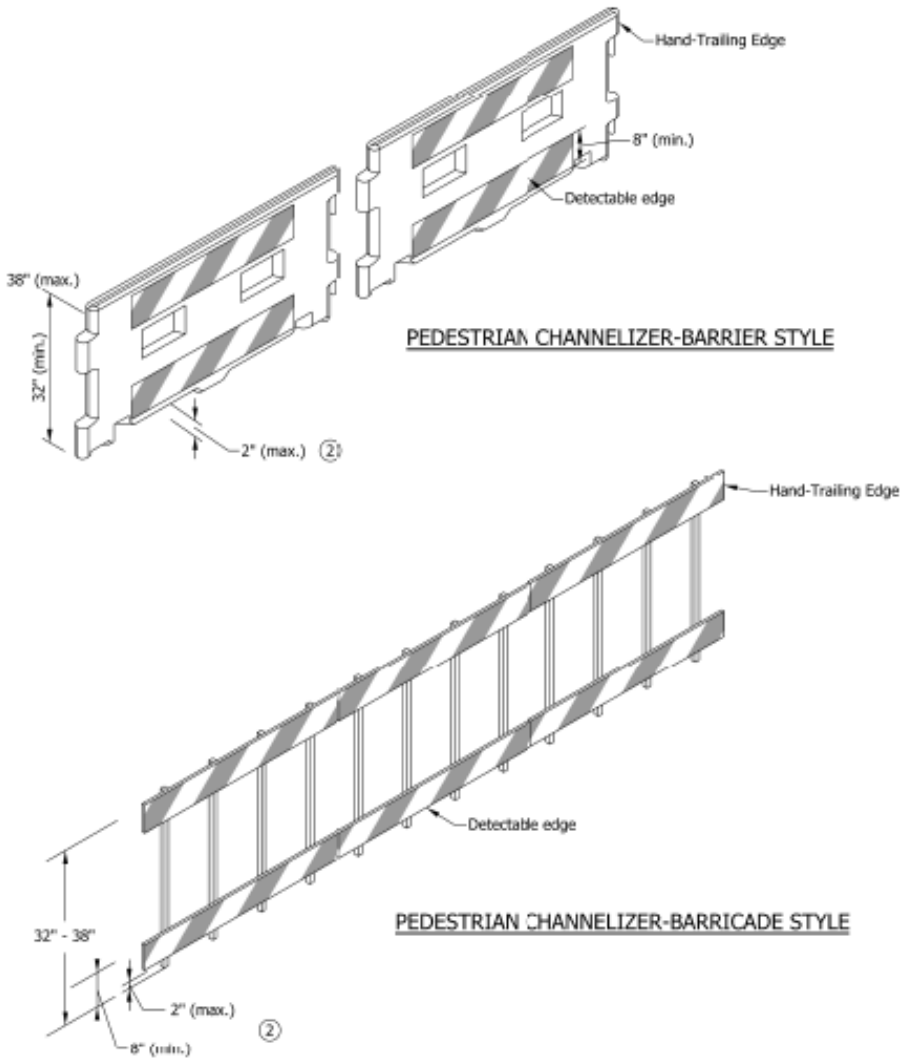

NOTES:

1. Ballast shall be located behind or internal to the device. Any support on the front of the device shall not extend into the 48 in. minimum walkway clear space and shall have 0.25 in. max. height above the walkway surface.
- ② Devices shall not block water drainage from the walkway. A gap height or opening from the walkway surface up to 2 in. max. height is allowed for drainage purposes.
3. Type III Barricades shall not be used as pedestrian channelizers.

INDIANA DEPARTMENT OF TRANSPORTATION					
TEMPORARY PEDESTRIAN CHANNELIZERS					
SEPTEMBER 2024					
STANDARD DRAWING NO. E 801-TPAR-12					
	<table border="0" style="width: 100%;"> <tr> <td style="border-top: 1px solid black; border-bottom: 1px solid black;">DESIGN STANDARDS ENGINEER</td> <td style="border-top: 1px solid black; border-bottom: 1px solid black;">DATE</td> </tr> <tr> <td style="border-top: 1px solid black; border-bottom: 1px solid black;">CHIEF ENGINEER</td> <td style="border-top: 1px solid black; border-bottom: 1px solid black;">DATE</td> </tr> </table>	DESIGN STANDARDS ENGINEER	DATE	CHIEF ENGINEER	DATE
DESIGN STANDARDS ENGINEER	DATE				
CHIEF ENGINEER	DATE				

COMMENTS AND ACTION

- 801-x-xxx TEMPORARY CURB RAMP (proposed new)
- 801-x-xxx TEMPORARY ACCESSIBLE PEDESTRIAN PATH (proposed new)
- 801-x-xxx TEMPORARY PEDESTRIAN CHANNELIZER (proposed new)
- 801-x-xxx AUDIBLE INFORMATION DEVICE (proposed new)
- E 801-TPAR series (proposed new)

DISCUSSION:

<p>Motion: Second: Ayes: Nays: FHWA Approval:</p>	<p>Action:</p> <ul style="list-style-type: none"> <input type="checkbox"/> Passed as Submitted <input type="checkbox"/> Passed as Revised <input type="checkbox"/> Withdrawn
<p>2024 Standard Specifications Sections: 801 begin pg. 867.</p>	<ul style="list-style-type: none"> <input type="checkbox"/> 2026 Standard Specifications <input type="checkbox"/> Revise Pay Items List <input type="checkbox"/> Notification to Designers if change is <u>not</u> addressed by RSP
<p>Recurring Special Provisions or Plan Details: Proposed new</p>	<ul style="list-style-type: none"> <input type="checkbox"/> Create RSP (No. __) Effective:
<p>Standard Drawing affected: Proposed new</p>	<ul style="list-style-type: none"> <input type="checkbox"/> Revise RSP (No. __) Effective:
<p>Design Manual Chapter: IDM §503-3.04(13)</p>	<ul style="list-style-type: none"> <input type="checkbox"/> Standard Drawing Effective:
<p>GIFE Section: 22</p>	<ul style="list-style-type: none"> <input type="checkbox"/> Create RPD (No. __) Effective: <input type="checkbox"/> GIFE Update <input type="checkbox"/> Frequency Manual Update <input type="checkbox"/> SiteManager Update

PROPOSAL TO STANDARDS COMMITTEE

PROBLEM(S) ENCOUNTERED: Moment slabs are permitted to have a concrete mix design in accordance with 501 or 502 and contractors generally choose 502. However, 502 does not require pozzolans which are essential for long term pavement durability.

PROPOSED SOLUTION:

Add a requirement in 706.02 that mixes for moment slabs shall include a pozzolan.

APPLICABLE STANDARD SPECIFICATIONS: 706.02, 706.04

APPLICABLE STANDARD DRAWINGS: none

APPLICABLE DESIGN MANUAL SECTION: none

APPLICABLE SECTION OF GIFE: none

APPLICABLE RECURRING SPECIAL PROVISIONS: none

PAY ITEMS AFFECTED: none

APPLICABLE SUB-COMMITTEE ENDORSEMENT: Ad hoc: Michael Nelson, Jim Reilman

IF APPROVED AS RECURRING SPECIAL PROVISION OR PLAN DETAILS, PROPOSED BASIS FOR USE:
Required for all contracts with a 706 Reinforced Concrete Moment Slab pay item

IMPACT ANALYSIS (attach report):

Submitted By: Jim Reilman

Title: State Materials Engineer

Organization: INDOT

Phone Number: (317) 522-9692

Date: 12/4/2023

IMPACT ANALYSIS REPORT CHECKLIST

*Explain the business case as to why this item should be presented to the Standards Committee for approval.
Answer the following questions with Yes, No or N/A.*

Does this item appear in any other specification sections? No

Will approval of this item affect the Approved Materials List? No

Will this proposal improve:

Construction costs? N/A

Construction time? N/A

Customer satisfaction? N/A

Congestion/travel time? N/A

Ride quality? N/A

Will this proposal reduce operational costs or maintenance effort? Yes

Will this item improve safety:

For motorists? N/A

For construction workers? N/A

Will this proposal improve quality for:

Construction procedures/processes? N/A

Asset preservation? Yes

Design process? N/A

Will this change provide the contractor more flexibility? N/A

Will this proposal provide clarification for the Contractor and field personnel? Yes

Can this item improve/reduce the number of potential change orders? Yes

Is this proposal needed for compliance with:

Federal or State regulations? No

AASHTO or other design code? No

Is this item editorial? No

Provide any further information as to why this proposal should be placed on the Standards Committee meeting Agenda:

REVISION TO 2024 STANDARD SPECIFICATIONS

SECTION 706 – BRIDGE RAILINGS

706.02 Materials

706.04 Concrete Railing with Reinforced Concrete Moment Slab

(Note: Proposed changes shown highlighted gray)

The Standard Specifications are revised as follows:

SECTION 706, BEGIN LINE 26, DELETE AND INSERT AS FOLLOWS:

The ~~C~~concrete mix design for reinforced concrete moment slabs shall be QC/QA PCCP in accordance with 501 or PCCP in accordance with 502 and shall include one or more pozzolans in accordance with the proportioning in 501.05.

SECTION 706, BEGIN LINE 109, DELETE AND INSERT AS FOLLOWS:

Job control testing for acceptance, concrete mixing, transportation, weather limitations, inspection, and opening to traffic shall be in accordance with 502.05.

AGENDA

COMMENTS AND ACTION

706.02 Materials
 706.04 Concrete Railing with Reinforced Concrete Moment Slab

DISCUSSION:

<p>Motion: Second: Ayes: Nays: FHWA Approval:</p>	<p><u>Action:</u> <input type="checkbox"/> Passed as Submitted <input type="checkbox"/> Passed as Revised <input type="checkbox"/> Withdrawn</p>
<p>2024 Standard Specifications Sections: 706 pg(s) 659 and 661.</p>	<p><input type="checkbox"/> 2026 Standard Specifications <input type="checkbox"/> Revise Pay Items List <input type="checkbox"/> Notification to Designers if change is <u>not</u> addressed by RSP</p>
<p>Recurring Special Provisions or Plan Details: 706-B-324 BRIDGE RAILINGS</p>	<p><input type="checkbox"/> Create RSP (No. __) Effective:</p>
<p>Standard Drawing affected: NONE</p>	<p><input type="checkbox"/> Revise RSP (No. __) Effective:</p>
<p>Design Manual Chapter: NONE</p>	<p><input type="checkbox"/> Standard Drawing Effective:</p>
<p>GIFE Section: NONE</p>	<p><input type="checkbox"/> Create RPD (No. __) Effective:</p>
	<p><input type="checkbox"/> GIFE Update <input type="checkbox"/> Frequency Manual Update <input type="checkbox"/> SiteManager Update</p>

PROPOSAL TO STANDARDS COMMITTEE

PROBLEM(S) ENCOUNTERED: It has been recently brought to the attention of Construction Management that Moment Slabs as defined in 706.04 have no specified smoothness requirement. Even though the smoothness of shoulders is required to be checked with a 16 ft straightedge when paving mainline with 401 or 501 HMA and PCCP mixes, when moment slabs consisting of PCCP are placed against HMA mainline uncertainty exists as to the required smoothness verification method. There are also some unnecessary references in this section of the specification that were causing issues in the field that require cleanup.

PROPOSED SOLUTION: Add a line to the moment slab requirements in spec section 706.04 requiring moment slab smoothness to be checked in accordance with 502.20 (16 ft straightedge). Clean up the references in the moment slab and bridge railing section that are unnecessary.

APPLICABLE STANDARD SPECIFICATIONS: 706.03, 04

APPLICABLE STANDARD DRAWINGS: N/A

APPLICABLE DESIGN MANUAL SECTION: N/A

APPLICABLE SECTION OF GIFE: N/A

APPLICABLE RECURRING SPECIAL PROVISIONS: N/A

PAY ITEMS AFFECTED: N/A

APPLICABLE SUB-COMMITTEE ENDORSEMENT: Ad Hoc: Clear Path Team, Pete White

IF APPROVED AS RECURRING SPECIAL PROVISION OR PLAN DETAILS, PROPOSED BASIS FOR USE:
Moment Slab pay item

IMPACT ANALYSIS (attach report):

Submitted By: Joe Novak

Title: State Construction Engineer

Organization: INDOT

Phone Number: 317-501-7805

Date: 12/5/23

IMPACT ANALYSIS REPORT CHECKLIST

Explain the business case as to why this item should be presented to the Standards Committee for approval. Answer the following questions with Yes, No or N/A.

Does this item appear in any other specification sections? 706.01, 706.02, 706.07, 706.08, 714.04, 723.04

Will approval of this item affect the Approved Materials List? No

Will this proposal improve:

Construction costs? No

Construction time? No

Customer satisfaction? Yes

Congestion/travel time? No

Ride quality? Yes

Will this proposal reduce operational costs or maintenance effort? No

Will this item improve safety:

For motorists? No

For construction workers? No

Will this proposal improve quality for:

Construction procedures/processes? Yes

Asset preservation? Yes

Design process? No

Will this change provide the contractor more flexibility? No

Will this proposal provide clarification for the Contractor and field personnel? Yes

Can this item improve/reduce the number of potential change orders? No

Is this proposal needed for compliance with:

Federal or State regulations? No

AASHTO or other design code? No

Is this item editorial? No

Provide any further information as to why this proposal should be placed on the Standards Committee meeting Agenda: N/A

REVISION TO 2024 STANDARD SPECIFICATIONS

SECTION 602 – CONCRETE BARRIER

602.03 Concrete Barrier and Concrete Glare Screen

SECTION 706 – BRIDGE RAILINGS

706.03 Concrete Railing

706.04 Concrete Railing with Reinforced Concrete Moment Slab

(Note: Proposed changes shown highlighted gray)

The Standard Specifications are revised as follows:

SECTION 602, BEGIN LINE 47, DELETE AS FOLLOWS:

(b) Cast-in-Place Concrete Barrier and Concrete Glare Screen

Cast-in-place concrete barrier and concrete glare screen shall be constructed in accordance with applicable requirements of 706.03 ~~or by the use of an approved slip form machine~~. The surfaces of the concrete shall vary no more than 1/4 in. in 10 ft from the specified cross-section, as measured from a longitudinal straightedge. Where concrete pavement or concrete shoulder abuts the concrete barrier, 1/2 in. preformed joint filler shall be placed as shown on the plans.

SECTION 706, BEGIN LINE 47, INSERT AS FOLLOWS:

Concrete bridge railing shall be built monolithically and continuous from support to support. A *butt joint or open joint* shall be provided at the end of the bridge between the bridge railing and the railing transition as shown on the plans. *The location of the joint shall coincide with the location and skew of the Type I-A or bridge expansion joint.*

SECTION 706, BEGIN LINE 71, INSERT AS FOLLOWS:

If joints are to be sawed, the full depth saw cut shall be made before uncontrolled shrinkage cracking occurs and within 48~~24~~ h of concrete placement. Before full depth sawing, partial depth saw cuts of 2 1/2 in. ±1/2 in. at the joint locations may be made as soon as the concrete has hardened sufficiently to enable sawing without raveling. All saw cuts shall be made at the locations shown on the plans or as directed.

All concrete bridge railings shall be *finished and* reflectorized in accordance with 602.03(c) *and* (f).

SECTION 706, BEGIN LINE 88, DELETE AND INSERT AS FOLLOWS:

706.04 Concrete Railing with Reinforced Concrete Moment Slab

The railing portion shall be *cast-in-place and* constructed in accordance with ~~602.03 except it shall be cast-in-place~~706.03. Type D-1 contraction joints in the moment slab shall match the locations of the joints in the abutting PCC pavement. If the abutting pavement is HMA, the D-1 contraction joints shall be spaced at 18 ft. The locations of the transverse joints in the moment slab and the railing shall be the same.

SECTION 706, BEGIN LINE 106, DELETE AND INSERT AS FOLLOWS:

Finishing and curing the moment slab shall be in accordance with 504. ~~Finishing and curing the railing shall be in accordance with 702.~~

Pavement smoothness of the moment slab shall be in accordance with 502.20.

SECTION 706, AFTER LINE 195, INSERT AS FOLLOWS:

REVISION TO 2024 STANDARD SPECIFICATIONS

SECTION 602 – CONCRETE BARRIER

602.03 Concrete Barrier and Concrete Glare Screen

SECTION 706 – BRIDGE RAILINGS

706.03 Concrete Railing

706.04 Concrete Railing with Reinforced Concrete Moment Slab

Furnishing and operating the 16 ft straightedge shall be included in the cost of other pay items within this section.

The cost of furnishing and placing all materials not specified as pay items shall be included in the cost of the pay items in this section.

AGENDA

COMMENTS AND ACTION

- 602.03 Concrete Barrier and Concrete Glare Screen
- 706.03 Concrete Railing
- 706.04 Concrete Railing with Reinforced Concrete Moment Slab

DISCUSSION:

<p>Motion: Second: Ayes: Nays: FHWA Approval:</p>	<p>Action:</p> <p><input type="checkbox"/> Passed as Submitted <input type="checkbox"/> Passed as Revised <input type="checkbox"/> Withdrawn</p>
<p>2024 Standard Specifications Sections: 602 pg. 495; 706 pg(s) 659, 661 and 663.</p> <p>Recurring Special Provisions or Plan Details: 706-B-324 BRIDGE RAILINGS</p> <p>Standard Drawing affected: NONE</p> <p>Design Manual Chapter: NONE</p> <p>GIFE Section: NONE</p>	<p><input type="checkbox"/> 2026 Standard Specifications Revise Pay Items List Notification to Designers if change is <u>not</u> addressed by RSP</p> <p><input type="checkbox"/> Create RSP (No. __) Effective:</p> <p><input type="checkbox"/> Revise RSP (No. __) Effective:</p> <p><input type="checkbox"/> Standard Drawing Effective:</p> <p><input type="checkbox"/> Create RPD (No. __) Effective:</p> <p><input type="checkbox"/> GIFE Update <input type="checkbox"/> Frequency Manual Update <input type="checkbox"/> SiteManager Update</p>

PROPOSAL TO STANDARDS COMMITTEE

PROBLEM(S) ENCOUNTERED: On bundled contracts or contracts with multiple bridges, sometimes there is considerable time that elapses between the time a polymeric bridge deck overlay is placed and the final acceptance date of the contract. This sometimes results in the contractor having to warranty the polymeric bridge deck overlay for much longer than the three years intended by the RSP.

PROPOSED SOLUTION: Revise RSP 738-B-297, section 738.13(b)4. to change from final acceptance date to substantial completion date and provide an alternative for the contractor when the contract completion date is more than one year after the completion of the polymeric overlay on a particular bridge that the contractor can submit a request for the warranty period to start.

APPLICABLE STANDARD SPECIFICATIONS: none

APPLICABLE STANDARD DRAWINGS: none

APPLICABLE DESIGN MANUAL SECTION: none

APPLICABLE SECTION OF GIFE:

APPLICABLE RECURRING SPECIAL PROVISIONS: existing RSP 738-B-297

PAY ITEMS AFFECTED: none

APPLICABLE SUB-COMMITTEE ENDORSEMENT: Ad hoc: Joe Novak, Jim Reilman, Dan Osborn ICI

IF APPROVED AS RECURRING SPECIAL PROVISION OR PLAN DETAILS, PROPOSED BASIS FOR USE: BFU to remain as-is.

IMPACT ANALYSIS (attach report):

Submitted By: Jim Reilman

Title: State Materials Engineer

Organization: INDOT

Phone Number: (317) 522-9692

Date: 12/5/23

IMPACT ANALYSIS REPORT CHECKLIST

Explain the business case as to why this item should be presented to the Standards Committee for approval. Answer the following questions with Yes, No or N/A.

Does this item appear in any other specification sections? No

Will approval of this item affect the Approved Materials List? No

Will this proposal improve:

Construction costs? Yes

Construction time? N/A

Customer satisfaction? N/A

Congestion/travel time? N/A

Ride quality? N/A

Will this proposal reduce operational costs or maintenance effort? N/A

Will this item improve safety:

For motorists? N/A

For construction workers? N/A

Will this proposal improve quality for:

Construction procedures/processes? N/A

Asset preservation? N/A

Design process? N/A

Will this change provide the contractor more flexibility? Yes

Will this proposal provide clarification for the Contractor and field personnel? Yes

Can this item improve/reduce the number of potential change orders? Yes

Is this proposal needed for compliance with:

Federal or State regulations? No

AASHTO or other design code? No

Is this item editorial? No

Provide any further information as to why this proposal should be placed on the Standards Committee meeting Agenda:

REVISION TO SPECIAL PROVISION

738-B-297 WARRANTED POLYMER OVERLAY SYSTEM FOR BRIDGE DECK SURFACES AND POLYMER OVERLAY SYSTEM FOR NON-BRIDGE DECKS

(Note: Proposed changes shown highlighted gray.
Only affected area are shown. Full content of currently used RSP [738-B-297](https://www.in.gov/dot/div/contracts/standards/rsp/sep23/sec700.htm) available at <https://www.in.gov/dot/div/contracts/standards/rsp/sep23/sec700.htm>)

738-B-297 WARRANTED POLYMER OVERLAY SYSTEM FOR BRIDGE DECK SURFACES AND POLYMER OVERLAY SYSTEM FOR NON-BRIDGE DECKS

(Revised 05-20-23)

The Standard Specifications are revised as follows:

SECTION 737, AFTER LINE 154, INSERT AS FOLLOWS:

SECTION 738 – WARRANTED POLYMER OVERLAY SYSTEM FOR BRIDGE DECK SURFACES AND POLYMER OVERLAY SYSTEM FOR OTHER CONCRETE SURFACES

738.01 Description

This work shall consist of cleaning and preparing a bridge deck surface and other, non-bridge deck surfaces, furnishing and mixing materials, and applying a two-coat polymer overlay system in accordance with 105.03.

[.....]

738.13 Performance Warranty

(a) General

The Contractor shall be responsible for and guarantee the performance of the polymer overlay system that has been applied to the bridge deck surface, as defined herein, for a period of three years after the initial acceptance date defined in 738.13(b)4. The Contractor shall warrant to the Department that the warranted work will be free of defects as measured by the condition parameters in 738.14(c)1 and not exceed the specified threshold values for each.

The performance warranty requirements for the polymer overlay system will not apply to an RCBA or other surfaces outside of the limits of the bridge deck surface.

The performance warranty and its provisions shall not be construed as extending or otherwise affecting the claim process and statute of limitations otherwise applicable to this contract.

(b) Definitions

The following definitions shall apply.

- 1. Bridge Deck Surface. The surface area contained within the out-to-out of coping width dimension and end-to-end of bridge floor length dimension. Items with raised vertical faces such as but not limited to bridge railings, sidewalks, curbs, median curbs, and barriers will not be*

REVISION TO SPECIAL PROVISION

738-B-297 WARRANTED POLYMER OVERLAY SYSTEM FOR BRIDGE DECK SURFACES AND POLYMER OVERLAY SYSTEM FOR NON-BRIDGE DECKS

considered part of the bridge deck surface for purposes of this specification.

2. *Conflict Resolution Team, CRT. A group consisting of five individuals whose sole responsibility is to provide a decision on disputes between the Department and the Contractor regarding application or fulfillment of the warranty requirements. The CRT is described in more detail in 738.15.*
3. *Delamination. Debonding of the polymer overlay system from the existing bridge deck surface.*
4. *Initial Acceptance Date. The same date as the date of ~~the final acceptance of the contract~~ substantial completion in accordance with 101.64. This date will be considered the start of the warranty period.*

Alternatively, when the completion date shown on the proposal page is more than one year later than the completed overlay and all work has been completed on a bridge such that it is open to unrestricted traffic, the Contractor may submit a written request to the Engineer for the warranty period to start. The Engineer will approve in writing within 14 calendar days provided all applicable contract requirements have been met and no initial issues have been observed. Any subsequent construction activity by the Contractor on a bridge where the warranty has started will void the requested warranty start date. Either a new warranty start date shall be requested or the warranty start date will revert to the substantial completion date.

5. *Scaling. Worn polymer overlay system surface with loss of epoxy and aggregate resulting in a reduction in thickness of the polymer overlay system greater than 20% of the initial overlay thickness.*
6. *Spalling. Broken or missing pieces of the polymer overlay system.*
7. *Warranted Work. The work product, polymer overlay system, that is guaranteed not to fall outside the specified thresholds of the condition parameters as defined in 738.14(c)1 during the warranty period.*
8. *Warranty Period. The three-year period of time the Contractor is required to ensure the performance of the polymer overlay system meets or exceeds the minimum specified threshold condition parameters as defined in 738.14(c)1.*
9. *Warranty Work. Corrective actions or remedial actions performed by the Contractor during the warranty period to bring the warranted work back*

REVISION TO SPECIAL PROVISION

738-B-297 WARRANTED POLYMER OVERLAY SYSTEM FOR BRIDGE DECK SURFACES AND POLYMER OVERLAY SYSTEM FOR NON-BRIDGE DECKS

into compliance with the specifications. All costs of warranty work shall be borne by the Contractor including traffic control, mobilization/demobilization, materials, pavement markings, and other incidental work and items. For purposes of this specification, the terms warranty work, corrective action, and remedial action are all interchangeable and shall have the same meaning.

[.....]

AGENDA

COMMENTS AND ACTION

738-B-297 WARRANTED POLYMER OVERLAY SYSTEM FOR BRIDGE DECK SURFACES AND POLYMER OVERLAY SYSTEM FOR NON-BRIDGE DECKS

DISCUSSION:

<p>Motion: Second: Ayes: Nays: FHWA Approval:</p>	<p>Action: <input type="checkbox"/> Passed as Submitted <input type="checkbox"/> Passed as Revised <input type="checkbox"/> Withdrawn</p>
<p>2024 Standard Specifications Sections: NONE</p>	<p><input type="checkbox"/> 2026 Standard Specifications <input type="checkbox"/> Revise Pay Items List <input type="checkbox"/> Notification to Designers if change is <u>not</u> addressed by RSP</p>
<p>Recurring Special Provisions or Plan Details: 738-B-297 WARRANTED POLYMER OVERLAY SYSTEM FOR BRIDGE DECK SURFACES AND POLYMER OVERLAY SYSTEM FOR NON-BRIDGE DECKS</p>	<p><input type="checkbox"/> Create RSP (No. __) Effective: <input type="checkbox"/> Revise RSP (No. __) Effective:</p>
<p>Standard Drawing affected: NONE</p>	<p><input type="checkbox"/> Standard Drawing Effective:</p>
<p>Design Manual Chapter: NONE</p>	<p><input type="checkbox"/> Create RPD (No. __) Effective:</p>
<p>GIFE Section: TBD</p>	<p><input type="checkbox"/> GIFE Update <input type="checkbox"/> Frequency Manual Update <input type="checkbox"/> SiteManager Update</p>

PROPOSAL TO STANDARDS COMMITTEE

PROBLEM(S) ENCOUNTERED: The cost of waterproofing membranes for reinforced concrete box structures and three-sided structures are currently included in the cost of these structures and are required when RSP 714-R-748 is included in the contract. INDOT has received feedback from ICI that it can be difficult to determine which structures within a contract are required to receive the waterproofing membrane, since this is often covered by plan notes that could easily be overlooked. The current practice of including the cost of the membrane in the cost of the structure also limits the Department's ability to monitor the cost of this treatment, which makes a cost/benefit analysis difficult.

PROPOSED SOLUTION: Update RSP 714-R-748 to pay for waterproofing membranes directly rather than including their cost in the structure.

APPLICABLE STANDARD SPECIFICATIONS: 714, 723, 918, all covered by RSP 714-R-748

APPLICABLE STANDARD DRAWING: 714-BCJT-01 (no changes required)

APPLICABLE DESIGN MANUAL CHAPTER: N/A

APPLICABLE SECTION OF GIFE: 4.1.2 (no changes required)

APPLICABLE RECURRING SPECIAL PROVISION OR PLAN DETAILS: RSP 714-R-748

PAY ITEMS AFFECTED: Two new pay items will be required; 'Waterproofing Membrane, Type 2' and 'Waterproofing Membrane, Type 3'

APPLICABLE SUB-COMMITTEE ENDORSEMENT: Ad hoc committee including Jeremy Hunter, Stephanie Wagner, Andrew Pinkstaff, and Jim Reilman

IF APPROVED AS RECURRING SPECIAL PROVISION OR PLAN DETAILS, PROPOSED BASIS FOR USE: As determined necessary by the Project Designer (same as current BFU)

IMPACT ANALYSIS (attach report):

Submitted By: Pete White

Title: Design Manager

Division: Bridge Engineering

E-mail: pewhite@indot.in.gov

Date: November 30, 2023

IMPACT ANALYSIS REPORT CHECKLIST

Explain the business case as to why this item should be presented to the Standards Committee for approval. Answer the following questions with Yes, No or N/A.

Does this item appear in any other specification sections? No

Will approval of this item affect the Qualified Products List (QPL)? No

Will this proposal improve:

Construction costs? No

Construction time? No

Customer satisfaction? No

Congestion/travel time? No

Ride quality? No

Will this proposal reduce operational costs or maintenance effort? No

Will this item improve safety:

For motorists? No

For construction workers? No

Will this proposal improve quality for:

Construction procedures/processes? Yes

Asset preservation? Yes

Design process? Yes

Will this change provide the contractor more flexibility? No

Will this proposal provide clarification for the Contractor and field personnel? Yes

Can this item improve/reduce the number of potential change orders? Yes

Is this proposal needed for compliance with:

Federal or State regulations? No

AASHTO or other design code? No

Is this item editorial? No

Provide any further information as to why this proposal should be placed on the Standards Committee meeting Agenda: This change will allow INDOT to track costs of this treatment and will minimize the risk of change orders during construction.

REVISION TO SPECIAL PROVISION

714-R-748 WATERPROOFING MEMBRANE FOR REINFORCED-CONCRETE BOX STRUCTURES AND THREE-SIDED STRUCTURES

(Note: Proposed changes shown highlighted gray)

714-R-748 WATERPROOFING MEMBRANE FOR REINFORCED-CONCRETE BOX STRUCTURES AND THREE-SIDED STRUCTURES

(Revised 05-20-23)

The Standard Specifications are revised as follows:

SECTION 714, AFTER LINE 20, INSERT AS FOLLOWS:

Fabric or Membrane for Waterproofing.....918.06

SECTION 714, AFTER LINE 361, DELETE AND INSERT AS FOLLOWS:

The pipe joint sealant shall be applied to the bell or spigot section of the structure and applied prior to joining segments. The volume of pipe joint sealant applied shall be in accordance with the manufacturer's recommendations.

(b) Exterior Surface Treatment

After sealing with pipe joint sealant and assembling the box sections, the outside surfaces of the top slab and both walls of every joint between structure sections shall be covered with a joint membrane in accordance with 907.07 that is centered on the joint, *unless a waterproofing membrane is shown on the plans or in the Schedule of Pay Items.* The exterior concrete box surface shall be clean and dry before the joint membrane is applied. The outside surfaces of the top slab and both walls of every joint shall be completely covered for the entire length of each joint. Where joining two sections of joint membrane material, or where two ends meet, a 3 in. overlap shall be provided. The overlapping strip shall be firmly pressed onto the end of the underlying strip to seal the joint. Joints between structure sections and wingwalls, between wingwalls and spandrel walls, and between structure sections and headwalls or spandrel walls shall also be covered with joint membrane. The manufacturer's application instructions shall apply in addition to the above requirements.

The joint membrane shall be maintained in its installed location centered on the joint and shall not be damaged or dislodged during the backfilling operation.

714.11 Waterproofing Membrane

When a waterproofing membrane is shown on the plans or in the Schedule of Pay Items, joints, exterior vertical surfaces, and the exterior top horizontal surface shall be covered in their entirety with the membrane. A Type 2 waterproofing membrane shall be installed on all exterior vertical surfaces. If asphalt is placed directly on top of the waterproofing membrane, a Type 3 waterproofing membrane shall be installed otherwise a Type 2 membrane shall be installed.

(a) Preparation

Concrete surfaces shall be prepared in accordance with the waterproofing membrane manufacturer's recommendations and the following. Concrete surfaces shall be smooth and free from projections and holes. All sharp edges and metal protrusions shall

REVISION TO SPECIAL PROVISION

714-R-748 WATERPROOFING MEMBRANE FOR REINFORCED-CONCRETE BOX STRUCTURES AND THREE-SIDED STRUCTURES

be ground smooth. Immediately prior to application, the surface shall be dry and free of dust and loose materials. All joints and exterior corners shall be prepared in accordance with the waterproofing membrane manufacturer's recommendations.

Prior to installing a Type 2 waterproofing membrane a prime coat recommended by the waterproofing membrane manufacturer shall be applied to all exterior surfaces that will receive the waterproofing membrane. Waterproofing membranes shall be installed when the ambient temperature is 40°F or above unless lower temperatures are allowed in accordance with the waterproofing membrane manufacturer's recommendations.

Type 3 waterproofing membranes shall be installed when the ambient temperature is 40°F or above. The surface shall be sufficiently dry so as to prevent the formation of steam when the hot-applied prime coat is applied.

(b) Installation

The waterproofing membrane shall be installed prior to backfilling.

For waterproofing membrane material that does not cover the surface, an overlap of at least 3 in. shall be required on all edges. The Type 2 or Type 3 waterproofing membrane from the top horizontal surface shall overlap the membrane on the vertical surfaces on the outside by at least 12 in. The manufacturer's application instructions shall apply in addition to the above requirements.

1. Type 2 Waterproofing Membrane

For a Type 2 waterproofing membrane, the release liner shall be removed, and the adhesive side shall be placed on the prepared concrete surface. After application, the waterproofing membrane material shall be rolled to avoid wrinkling and ensure adhesion of the membrane to the concrete.

2. Type 3 Waterproofing Membrane

For a Type 3 waterproofing membrane, the prime coat shall be applied no farther than 5 ft in front of the membrane, using a squeegee to fill all voids and imperfections. The waterproofing membrane shall be applied from the low to the high side of the surface. An extra bead of prime coat material shall be applied at the edge of the waterproofing membrane.

Prime coat material and waterproofing membrane shall stop a uniform distance below the top surfaces and shall overlap the Type 2 waterproofing membrane a minimum of 12 in. The prime coat material shall not be splattered over or applied to surfaces or faces of concrete which subsequently are exposed in the finished structure. The waterproofing membrane shall be placed in V-strips at the joints to allow the movement of adjacent concrete sections without tearing the membrane. The waterproofing membrane shall be flashed at all exposed edges and laps sealed down. The waterproofing membrane shall not be damaged when backfill is placed. After installing the waterproofing membrane over the entire surface, all joints in the membrane shall be sealed by applying a prime coat

REVISION TO SPECIAL PROVISION

714-R-748 WATERPROOFING MEMBRANE FOR REINFORCED-CONCRETE BOX STRUCTURES AND THREE-SIDED STRUCTURES

and smoothing with a V-squeegee.

On structures with curbs, the waterproofing membrane shall be placed 3 in. up the curb face and the edge of the membrane shall be sealed in accordance with the waterproofing membrane manufacturer’s recommendation.

Tack coat, in accordance with 406, shall be applied to a Type 3 waterproofing membrane, without damaging the membrane at an application rate of 0.05 to 0.08 gal./sq yd before placing any asphalt pavement.

714.112 Method of Measurement

Precast reinforced concrete box structures or structure extensions, precast coated reinforced concrete box structures or structure extensions, precast headwalls, precast wingwalls, cast-in-place reinforced concrete box structures or structure extensions, cast-in-place coated reinforced concrete box structures or structure extensions, cast-in-place headwalls, and cast-in-place wingwalls will not be measured. The accepted quantities for payment will be the quantities shown on the plans.

Waterproofing membrane will not be measured. The accepted quantities for payment will be the quantities shown in the Schedule of Pay Items, which will be based on nominal surface area to receive the membrane as shown on the plans and described herein. No adjustments in quantities will be made to account of overlapping portions of membrane or changes in surface area due to variations between nominal plan and furnished structure geometry.

SECTION 714, BEGIN LINE 406, DELETE AND INSERT AS FOLLOWS:

714.1213 Basis of Payment

SECTION 714, AFTER LINE 437, INSERT AS FOLLOWS:

Waterproofing Membrane, SFT
type

The cost of excavation except as provided in 206.11(a), expansion joint material, perpetuation of existing drains shown on the plans, removal of portions of existing structures, cleaning out old channels or structures, ~~waterproofing membrane, prime coat,~~ chemical anchor system, precast reinforced concrete structure joints, pipe joint sealant, joint membrane, and necessary incidentals shall be included in the cost of the structure or structure extension.

The cost of the prime coat shall be included in the cost of the waterproofing membrane.

SECTION 723, AFTER LINE 24, INSERT AS FOLLOWS:

Fabric or Membrane for Waterproofing.....918.06

SECTION 723, BEGIN LINE 90, DELETE AND INSERT AS FOLLOWS:

REVISION TO SPECIAL PROVISION

714-R-748 WATERPROOFING MEMBRANE FOR REINFORCED-CONCRETE BOX STRUCTURES AND THREE-SIDED STRUCTURES

723.03 General Requirements

Excavation and disposal shall be in accordance with the applicable requirements of 206. *Waterproofing membranes shall be in accordance with 714.11. Waterproofing of the designated areas shall be in accordance with 702.23.* All underground drains encountered during excavation for the structure shall be perpetuated as dictated by field conditions. Drainage openings through masonry shall be in accordance with 702.16. Handling of three-sided structures shall be in accordance with 907.05. Handling of wingwalls and spandrel walls shall be in accordance with 907.06.

SECTION 723, BEGIN LINE 430, DELETE AND INSERT AS FOLLOWS:

(b) Exterior Surface Treatment

After sealing with preformed flexible joint sealant or non-shrink grout as directed above, and assembly of three-sided structure sections, all butt and keyway joints between structure sections shall be covered with a joint membrane in accordance with 907.07 and centered on the joint, *unless a waterproofing membrane is shown on the plans or in the Schedule of Pay Items.*

The exterior surface of the concrete sections shall be clean and dry before the joint membrane is applied. The outside surfaces of the top slab and both walls of every joint shall be completely covered for the entire length of each joint. Where joining two sections of joint membrane material, or where two ends meet, a 3 in. overlap shall be provided. The overlapping strip shall be firmly pressed onto the end of the underlying strip to seal the joint. Joints between structure sections and wingwalls, between wingwalls and spandrel walls, and between structure sections and headwalls or spandrel walls shall also be covered with a joint membrane.

The joint membrane shall be maintained in its installed location centered on the joint. It shall not be damaged during the backfilling operation.

When shown on the plans or in the Schedule of Pay Items, all joints, exterior vertical surfaces, and exterior top surfaces shall be covered in their entirety with a waterproofing membrane in accordance with 714.11.

SECTION 723, BEGIN LINE 448, INSERT AS FOLLOWS:

723.15 Backfilling

Waterproofing membrane shall be applied prior to backfilling. Structure backfill shall be placed and compacted in accordance with 211. Structure backfill shall be placed and compacted on each side of the structure to the fill line shown on the plans. During the backfill operation, the difference in elevations of the fill on each side of the structure shall not exceed 24 in.

SECTION 723, AFTER LINE 478, INSERT AS FOLLOWS:

Waterproofing membrane will not be measured. The accepted quantity for payment will be in accordance with 714.12.

SECTION 723, AFTER LINE 510, INSERT AS FOLLOWS:

REVISION TO SPECIAL PROVISION

714-R-748 WATERPROOFING MEMBRANE FOR REINFORCED-CONCRETE BOX STRUCTURES AND THREE-SIDED STRUCTURES

Waterproofing membrane will be paid for in accordance with 714.13.

SECTION 723, BEGIN LINE 533, INSERT AS FOLLOWS:

The cost of all design, coring, testing, pedestals or extended legs, excavation, repairs, plugging core and handling holes, mortar, grout, sealer, ~~waterproofing membrane, prime coat~~, preformed flexible joint sealant, joint membrane, cylinder molds, and necessary incidentals shall be included in the cost of the structure or structure extension.

SECTION 918, BEGIN LINE 114, DELETE AND INSERT AS FOLLOWS:

918.06 Fabric or Membrane for Waterproofing

~~Fabric for~~ Type 1 waterproofing membrane shall be consist of a Utility Asphalt, UA-1 in accordance with 902.01(d) and a fabric consisting of treated cotton in accordance with ASTM D173, woven glass in accordance with ASTM D1668, or glass fiber mat in accordance with ASTM D2178. A Type C certification in accordance with 916 shall be provided for the ~~fabric~~ Type 1 material.

Type 2 waterproofing membrane shall consist of a rubberized asphalt and peel-and-stick membrane. Membrane materials shall be stored indoors and at temperatures not to exceed 120°F.

PROPERTY	TEST METHOD	REQUIREMENTS
Thickness	ASTM D1777 or ASTM D3767	60 mils, min.
Width		24 in., min.
Pliability		Shall be installed over 40 °F
Elongation	ASTM D412 (Die C)	300%, min.
Puncture Resistance – Membrane	ASTM E154	35 lb min.
Permeance	ASTM E96, Method B	0.05 Perms, max.
Water Absorption, % by Weight	ASTM D570	0.2, max.
Adhesion to concrete	ASTM D903	5.0, min.

Type 3 waterproofing membrane shall consist of a hot-applied joint prime coat in accordance with ASTM D6690 and a membrane consisting of a high-density asphalt mastic between two layers of polymeric fabric. The membrane and prime coat materials shall be kept dry prior to installation.

PROPERTY	TEST METHOD	REQUIREMENTS
Thickness, min.	ASTM D1777	0.135 in.
Width, min.		24 in.
Weight, min.		0.8 lb/sq ft
Tensile strength, machine direction	ASTM D882, Modified ^[1]	275 lb/in. 2,000 psi
Tensile strength, 90 ° to	ASTM D882, Modified ^[1]	150 lb/in.

REVISION TO SPECIAL PROVISION

714-R-748 WATERPROOFING MEMBRANE FOR REINFORCED-CONCRETE BOX STRUCTURES AND THREE-SIDED STRUCTURES

<i>machine direction</i>		<i>1,000 psi</i>
<i>Elongation at break</i>	<i>ASTM D882, Modified^[1]</i>	<i>100% min.</i>
<i>Brittleness</i>	<i>ASTM D517</i>	<i>Pass</i>
<i>Softening point (mastic)</i>	<i>ASTM D36</i>	<i>200 °F min.</i>
<i>Peel adhesion</i>	<i>ASTM D413^[1]</i>	<i>2.0 lb/in.</i>
<i>Cold flex</i>	<i>ASTM D146 2 x 5 in. specimen</i>	<i>180 ° bend over 2-in. mandrel with no cracking</i>
<i>Heat stability</i>	<i>2 x 5 in. specimen</i>	<i>vertically suspended in a mechanical convection oven 2 hr @ 190 °F with no dripping or delamination</i>
<i>[1] 12 in. per minute test speed and 1 in. initial distance between the grips.</i>		

A Type B Certification in accordance with 916 shall be provided for the Type 2 and Type 3 material.

COMMENTS AND ACTION

714-R-748 WATERPROOFING MEMBRANE FOR REINFORCED-CONCRETE BOX STRUCTURES AND THREE-SIDED STRUCTURES

DISCUSSION:

<p>Motion: Second: Ayes: Nays: FHWA Approval:</p>	<p><u>Action:</u> <input type="checkbox"/> Passed as Submitted <input type="checkbox"/> Passed as Revised <input type="checkbox"/> Withdrawn</p>
<p>2024 Standard Specifications Sections: 714 begin pg. 723; 723 begin pg. 794; 918.06 begin pg. 1141. Recurring Special Provisions or Plan Details: 714-R-748 WATERPROOFING MEMBRANE FOR REINFORCED-CONCRETE BOX STRUCTURES AND THREE-SIDED STRUCTURES Standard Drawing affected: 714-BCJT-01 (no changes required) Design Manual Chapter: NONE</p>	<p><input type="checkbox"/> 2026 Standard Specifications <input type="checkbox"/> Revise Pay Items List <input type="checkbox"/> Notification to Designers if change is <u>not</u> addressed by RSP <input type="checkbox"/> Create RSP (No. __) Effective: <input type="checkbox"/> Revise RSP (No. __) Effective: <input type="checkbox"/> Standard Drawing Effective: <input type="checkbox"/> Create RPD (No. __) Effective:</p>
<p>GIFE Section: 4.1.2 (no changes required)</p>	<p><input type="checkbox"/> GIFE Update <input type="checkbox"/> Frequency Manual Update <input type="checkbox"/> SiteManager Update</p>

PROPOSAL TO STANDARDS COMMITTEE

PROBLEM(S) ENCOUNTERED:

The recent fire that resulted in the closure of a bridge on the Santa Monica Freeway in Los Angeles, California, has caused the detour of approximately 290,000 vehicles a day, adversely affecting the lives of local travelers and regional economies. Although the investigation is still ongoing, this incident appears to be very similar to the fire that resulted in the 2017 collapse of an interstate bridge in Atlanta, Georgia. This event in California again raises serious concerns about storing materials, including flammable, explosive, or hazardous materials, under bridges and other elevated structures.

PROPOSED SOLUTION:

Include a specification addition within SS 106.05, Storage of Materials. Where the Department would restrict the storage of flammable, inflammable or combustible materials within 50 ft of a bridge or an overhead sign structure. These materials include but are not limited to fuel, paint, solvents, fertilizer, pvc products, wood and timber not currently being used for falsework. Furthermore, a restriction would be added to Contractor stored equipment. Where no Contractor equipment, equipped with a fuel tank shall be stored beneath a bridge or overhead sign structure when workers are not present.

APPLICABLE STANDARD SPECIFICATIONS: SS 106.05 Storage of Materials

APPLICABLE STANDARD DRAWING: NA

APPLICABLE DESIGN MANUAL CHAPTER: NA

APPLICABLE SECTION OF GIFE: NA

APPLICABLE RECURRING SPECIAL PROVISION OR PLAN DETAILS: NA

PAY ITEMS AFFECTED: NA

APPLICABLE SUB-COMMITTEE ENDORSEMENT: NA

IF APPROVED AS RECURRING SPECIAL PROVISION OR PLAN DETAILS, PROPOSED BASIS FOR USE: NA

IMPACT ANALYSIS (attach report): Yes

Submitted By: Joe Novak
Title: State Construction Engineer
Division: Construction Management
E-mail: JNovak@indot.in.gov
Date: 12/11/2023

IMPACT ANALYSIS REPORT CHECKLIST

Explain the business case as to why this item should be presented to the Standards Committee for approval. Answer the following questions with Yes, No or N/A.

Does this item appear in any other specification sections? No

Will approval of this item affect the Qualified Products List (QPL)? No

Will this proposal improve:

Construction costs? No

Construction time? No

Customer satisfaction? No

Congestion/travel time? Yes

Ride quality? No

Will this proposal reduce operational costs or maintenance effort? No

Will this item improve safety:

For motorists? Yes

For construction workers? Yes

Will this proposal improve quality for:

Construction procedures/processes? No

Asset preservation? Yes

Design process? No

Will this change provide the contractor more flexibility? No

Will this proposal provide clarification for the Contractor and field personnel? Yes

Can this item improve/reduce the number of potential change orders? No

Is this proposal needed for compliance with:

Federal or State regulations? Yes

AASHTO or other design code? No

Is this item editorial? No

Provide any further information as to why this proposal should be placed on the Standards Committee meeting Agenda: NA

REVISION TO 2024 STANDARD SPECIFICATIONS

SECTION 106 – CONTROL OF MATERIAL

106.05 Storage of Materials

(Note: Proposed changes shown highlighted gray)

The Standard Specifications are revised as follows:

SECTION 106, BEGIN LINE 213, INSERT AS FOLLOWS:

106.05 Storage of Materials

Storage of materials shall be such that will assure the preservation of their quality and fitness for the work. When considered necessary, materials shall be placed on raised, clean platforms, constructed of wood or other hard surfaced material, and under cover. Stored materials shall be located to facilitate proper inspection. Materials to be used for all contracts shall be stored separately and intact and, after being tested for such work, shall not be used for other purposes except unless otherwise approved.

No flammable, inflammable, or combustible materials shall be stored within 50 ft of a bridge or overhead sign structure. Such materials shall be stored in accordance with directions from the manufacturer. These materials include but are not limited to fuel, paint, solvents, fertilizer, pvc products, wood and timber not currently being used for falsework. No Contractor equipment, equipped with a fuel tank shall be stored beneath a bridge or overhead sign structure when workers are not present.

The portion of the right-of-way not required for public travel may be used for storage purposes and for placing the Contractor's plant and equipment, subject to requirements set out in 107.08 and only by written request. Approval will be based on compliance with 107.08 and the Contractor's proposed procedure for re-establishing vegetation in the affected area to its original condition or better. Except as provided in 105.07 and except where necessary for drainage, if storage limits are shown on the plans, the right-of-way within such storage limits will be available for construction operations and storage of materials. Private property shall not be used for storage purposes without written permission of the owner or lessee. If requested, copies of such written permission shall be furnished. All storage sites shall be restored to their original condition with no additional payment.

COMMENTS AND ACTION

106.05 Storage of Materials

DISCUSSION:

<p>Motion: Second: Ayes: Nays: FHWA Approval:</p>	<p>Action:</p> <p><input type="checkbox"/> Passed as Submitted <input type="checkbox"/> Passed as Revised <input type="checkbox"/> Withdrawn</p>
<p>2024 Standard Specifications Sections: 106 begin pg. 63.</p>	<p><input type="checkbox"/> 2026 Standard Specifications <input type="checkbox"/> Revise Pay Items List <input type="checkbox"/> Notification to Designers if change is <u>not</u> addressed by RSP</p>
<p>Recurring Special Provisions or Plan Details: NONE</p>	<p><input type="checkbox"/> Create RSP (No. __) Effective:</p>
<p>Standard Drawing affected: NONE</p>	<p><input type="checkbox"/> Revise RSP (No. __) Effective:</p>
<p>Design Manual Chapter: NONE</p>	<p><input type="checkbox"/> Standard Drawing Effective:</p>
<p>GIFE Section: NONE</p>	<p><input type="checkbox"/> Create RPD (No. __) Effective:</p>
	<p><input type="checkbox"/> GIFE Update <input type="checkbox"/> Frequency Manual Update <input type="checkbox"/> SiteManager Update</p>

PROPOSAL TO STANDARDS COMMITTEE

PROBLEM(S) ENCOUNTERED: Standard Drawing needed to illustrate partial coating (painting) limits for existing steel beams as part of semi-integral end bent conversion. Revisions to *Standard Specifications* 619 were approved February 2023. A sketch was agreed upon, but Standard Drawing was not created. Designers are currently showing limits on the construction plans.

Subsequent painting terminology was approved July 2023 and will be incorporated into the Standard Drawings series.

PROPOSED SOLUTION: Add details to Standard Drawings series 619-PRWS

APPLICABLE STANDARD SPECIFICATIONS: 619 (no revisions required)

APPLICABLE STANDARD DRAWING: 619-PRWS

APPLICABLE DESIGN MANUAL CHAPTER: 17 (revisions incorporated in DM 23-10, Aug. 2023)

APPLICABLE SECTION OF GIFE: N/A

APPLICABLE RECURRING SPECIAL PROVISION OR PLAN DETAILS: N/A

PAY ITEMS AFFECTED: N/A

APPLICABLE SUB-COMMITTEE ENDORSEMENT: Ad Hoc Elizabeth Mouser, Pete White

IF APPROVED AS RECURRING SPECIAL PROVISION OR PLAN DETAILS, PROPOSED BASIS FOR USE:

IMPACT ANALYSIS (attach report):

Submitted By: Pete White

Title: Bridge Design Manager

Division: Bridge Engineering

E-mail: pewwhite@indot.in.gov

Date: 12/22/2023

IMPACT ANALYSIS REPORT CHECKLIST

Explain the business case as to why this item should be presented to the Standards Committee for approval. Answer the following questions with Yes, No or N/A.

Does this item appear in any other specification sections? No

Will approval of this item affect the Qualified Products List (QPL)? No

Will this proposal improve:

Construction costs? Yes

Construction time? Yes

Customer satisfaction? Yes

Congestion/travel time? No

Ride quality? No

Will this proposal reduce operational costs or maintenance effort? Yes

Will this item improve safety:

For motorists? No

For construction workers? No

Will this proposal improve quality for:

Construction procedures/processes? Yes

Asset preservation? Yes

Design process? Yes

Will this change provide the contractor more flexibility? Yes

Will this proposal provide clarification for the Contractor and field personnel? Yes

Can this item improve/reduce the number of potential change orders? Yes

Is this proposal needed for compliance with:

Federal or State regulations? No

AASHTO or other design code? No

Is this item editorial? Terminology revisions (painting to coating) on existing 619-PRWS-01 are considered editorial.

Provide any further information as to why this proposal should be placed on the Standards Committee meeting Agenda: No.

REVISION TO STANDARD DRAWINGS

E 619-PRWS-01 PAINTING REQUIREMENTS FOR WEATHERING STEEL (shown markups)

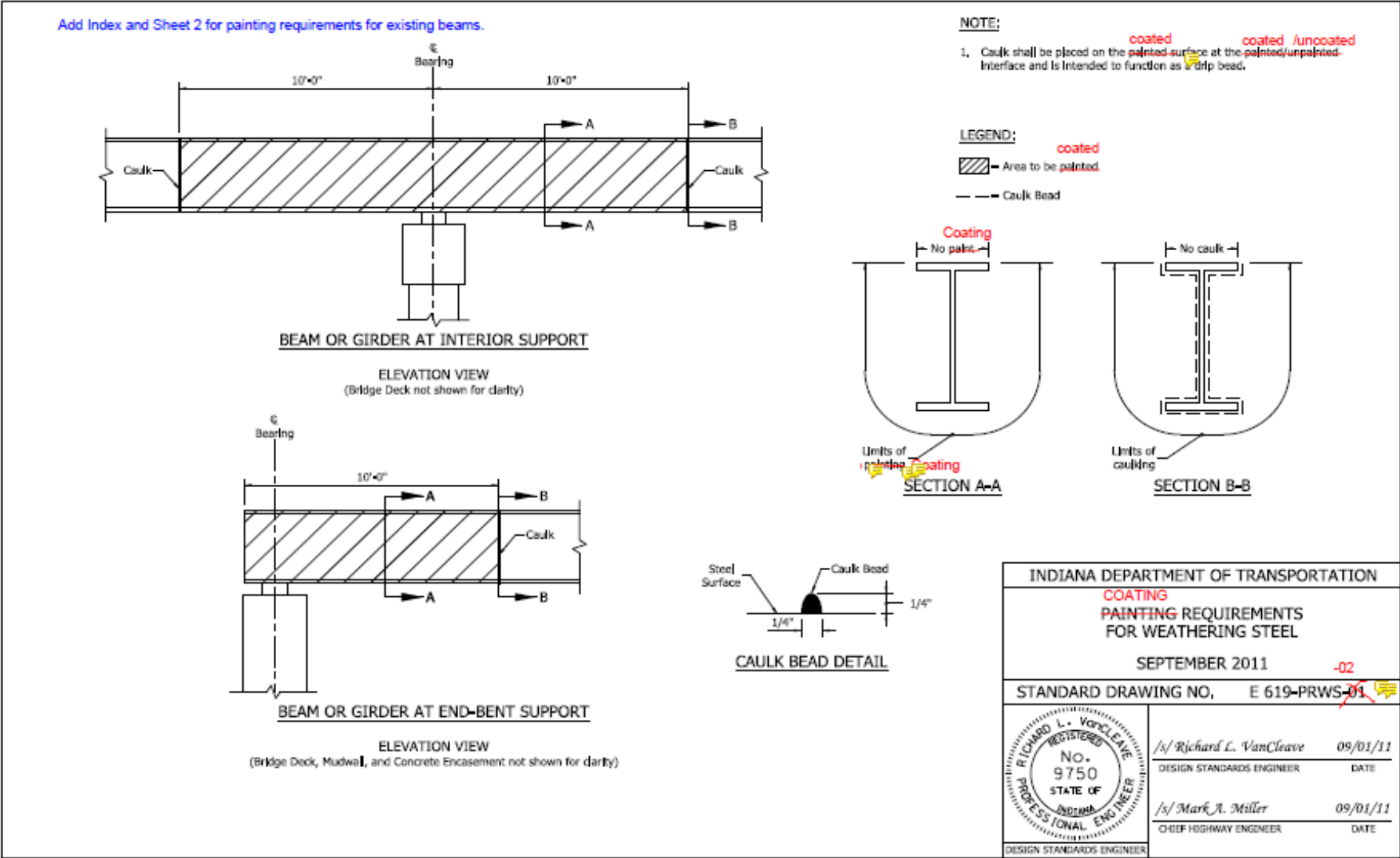

REVISION TO STANDARD DRAWINGS

E 619-PRWS-01 COATING REQUIREMENTS FOR STRUCTURAL STEEL INDEX (proposed draft)

INDEX	
SHEET NO.	SUBJECT
1	COATING REQUIREMENTS FOR STRUCTURAL STEEL INDEX
2	COATING REQUIREMENTS FOR WEATHERING STEEL
3	COATING REQUIREMENTS FOR EXISTING STRUCTURAL STEEL ENCASED IN CONCRETE

INDIANA DEPARTMENT OF TRANSPORTATION	
COATING REQUIREMENTS FOR STRUCTURAL STEEL INDEX SEPTEMBER 2024	
STANDARD DRAWING NO, E 619-PRWS-01	
	DESIGN STANDARDS ENGINEER DATE
	CHIEF ENGINEER DATE

REVISION TO STANDARD DRAWINGS

E 619-PRWS-02 COATING REQUIREMENTS FOR WEATHERING STEEL (proposed draft)

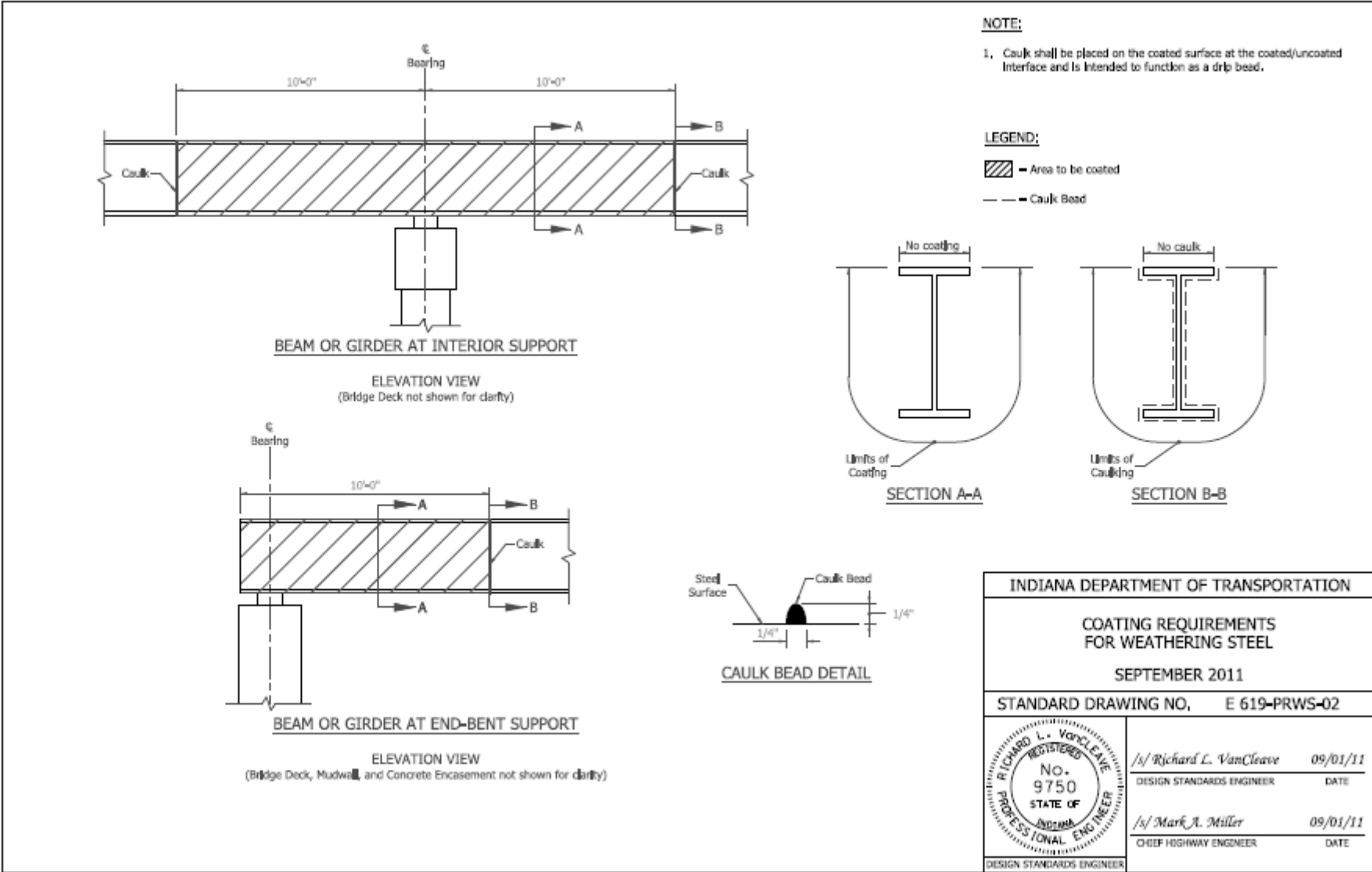

INDIANA DEPARTMENT OF TRANSPORTATION	
COATING REQUIREMENTS FOR WEATHERING STEEL	
SEPTEMBER 2011	
STANDARD DRAWING NO, E 619-PRWS-02	
	/s/ Richard L. VanCleave 09/01/11
	DESIGN STANDARDS ENGINEER DATE
	/s/ Mark A. Miller 09/01/11
DESIGN STANDARDS ENGINEER	CHIEF HIGHWAY ENGINEER DATE

REVISION TO STANDARD DRAWINGS

E 619-PRWS-03 COATING REQUIREMENTS FOR EXISTING STRUCTURAL STEEL ENCASED IN CONCRETE (proposed draft)

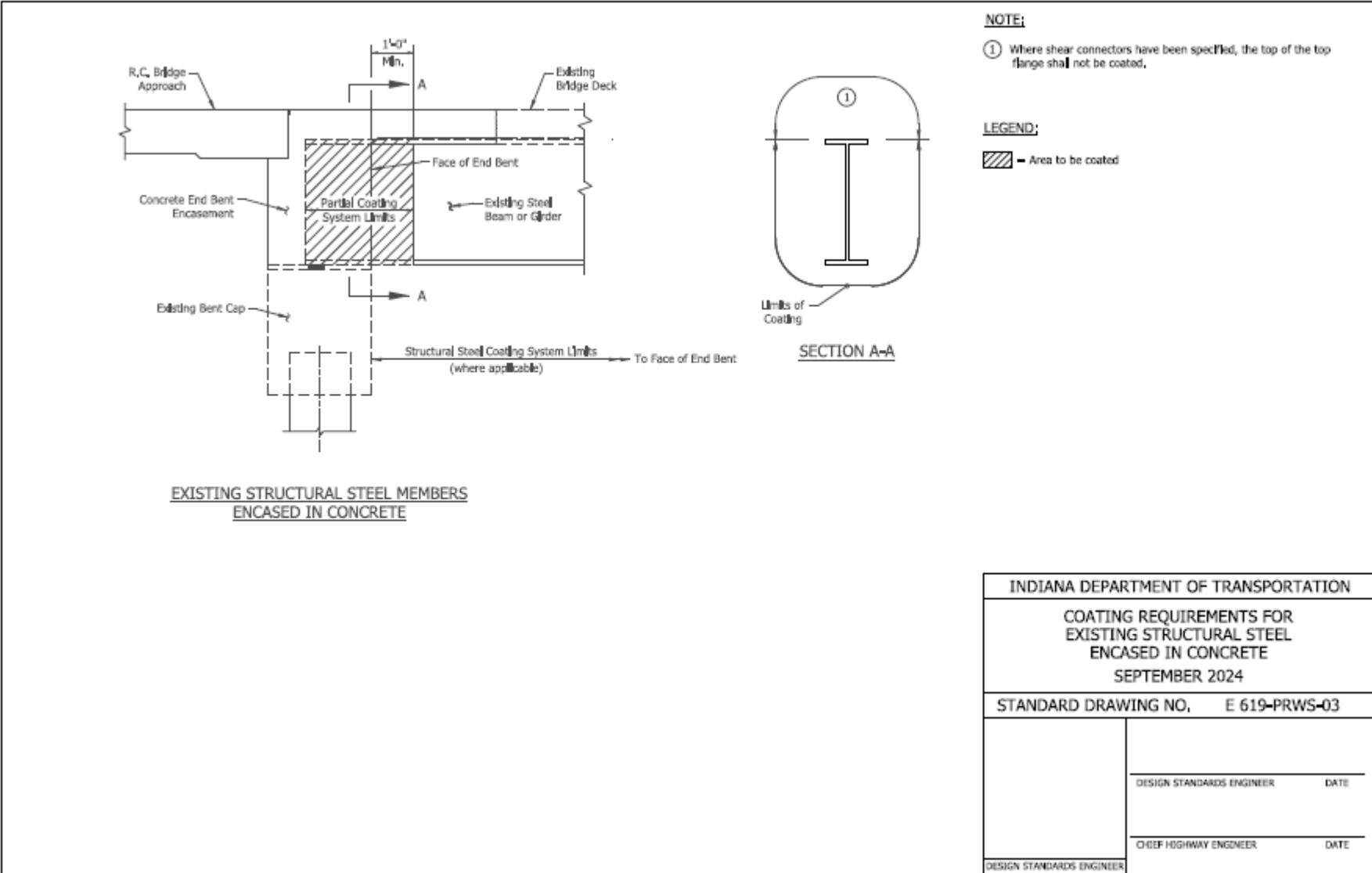

COMMENTS AND ACTION

E 619-PRWS-01 thru -03 COATING REQUIREMENTS FOR STRUCTURAL STEEL

DISCUSSION:

<p>Motion: Second: Ayes: Nays: FHWA Approval:</p>	<p><u>Action:</u> <input type="checkbox"/> Passed as Submitted <input type="checkbox"/> Passed as Revised <input type="checkbox"/> Withdrawn</p>
<p>2024 Standard Specifications Sections: 619 begin pg. 541.</p> <p>Recurring Special Provisions or Plan Details: NONE</p> <p>Standard Drawing affected: 619-PRWS (proposed new)</p> <p>Design Manual Chapter: 17</p> <p>GIFE Section: NONE</p>	<p><input type="checkbox"/> 2026 Standard Specifications <input type="checkbox"/> Revise Pay Items List <input type="checkbox"/> Notification to Designers if change is <u>not</u> addressed by RSP</p> <p><input type="checkbox"/> Create RSP (No. __) Effective:</p> <p><input type="checkbox"/> Revise RSP (No. __) Effective:</p> <p><input type="checkbox"/> Standard Drawing Effective:</p> <p><input type="checkbox"/> Create RPD (No. __) Effective:</p> <p><input type="checkbox"/> GIFE Update <input type="checkbox"/> Frequency Manual Update <input type="checkbox"/> SiteManager Update</p>

PROPOSAL TO STANDARDS COMMITTEE

PROBLEM(S) ENCOUNTERED: Edits to the QPLs addressing coatings and coating systems were made. This resulted in some minor confusion with the furnishing and use of zinc primers in the 909.02(a) section.

PROPOSED SOLUTION: incorporate the proposed edits to clarify which QPL has inorganic zinc primers and which has organic zinc primers.

APPLICABLE STANDARD SPECIFICATIONS: 909.02(a)3

APPLICABLE STANDARD DRAWINGS: none

APPLICABLE DESIGN MANUAL SECTION: none

APPLICABLE SECTION OF GIFE: none

APPLICABLE RECURRING SPECIAL PROVISIONS: 619-B-321

PAY ITEMS AFFECTED: none

APPLICABLE SUB-COMMITTEE ENDORSEMENT: Ad hoc: Kelly Cummins, David Jacobs, Jim Reilman

IF APPROVED AS RECURRING SPECIAL PROVISION OR PLAN DETAILS, PROPOSED BASIS FOR USE: this proposal edits the existing RSP, therefore the BFU can remain as-is.

IMPACT ANALYSIS (attach report):

Submitted By: Jim Reilman

Title: State Materials Engineer

Organization: INDOT

Phone Number: (317) 522-9692

Date: 12/18/23

IMPACT ANALYSIS REPORT CHECKLIST

Explain the business case as to why this item should be presented to the Standards Committee for approval. Answer the following questions with Yes, No or N/A.

Does this item appear in any other specification sections? No

Will approval of this item affect the Approved Materials List? No

Will this proposal improve:

Construction costs? N/A

Construction time? N/A

Customer satisfaction? N/A

Congestion/travel time? N/A

Ride quality? N/A

Will this proposal reduce operational costs or maintenance effort? N/A

Will this item improve safety:

For motorists? N/A

For construction workers? N/A

Will this proposal improve quality for:

Construction procedures/processes? N/A

Asset preservation? N/A

Design process? N/A

Will this change provide the contractor more flexibility? N/A

Will this proposal provide clarification for the Contractor and field personnel? Yes

Can this item improve/reduce the number of potential change orders? Yes

Is this proposal needed for compliance with:

Federal or State regulations? No

AASHTO or other design code? No

Is this item editorial? No

Provide any further information as to why this proposal should be placed on the Standards Committee meeting Agenda:

REVISION TO RECURRING SPECIAL PROVISION

619-B-321 BRIDGE PAINTING

(Note: Proposed changes shown highlighted gray.
Only affected area are shown. Full content of currently used RSP [619-B-321](https://www.in.gov/dot/div/contracts/standards/rsp/sep23/sec600.htm) available at <https://www.in.gov/dot/div/contracts/standards/rsp/sep23/sec600.htm>)

619-B-321 BRIDGE PAINTING

(Adopted 07-20-23)

The Standard Specifications are revised as follows:

[-----]

SECTION 909, BEGIN LINE 107, DELETE AND INSERT AS FOLLOWS:

The infrared spectrum of the vehicle *component* when extracted from the organic zinc primer, in accordance with ASTM D3168, shall match the infrared spectrum of the vehicle *component* of the sample submitted for formulation approval.

The cured film shall not contain any toxic heavy metals above the limits of the regulatory levels of 40 CFR 261.24, Table 1. The cured ~~paint~~ coating shall not contain any other material which will require characterization as a hazardous waste for the disposal of the dried film.

3. Furnishing and Use

Inorganic zinc primers shall be part of a structural steel coating system. Only inorganic zinc primers listed on the QPL of Structural Steel Coating Systems shall be used.

When organic zinc primers are specified, Only organic zinc primers from the QPL of Coating Formulations shall be used. ~~Z~~Organic Zinc primers will be placed and maintained on the QPL of Coating Formulations in accordance with ITM 606.

~~SECTION 909, BEGIN LINE 121, DELETE AND INSERT AS FOLLOWS:~~

(b) Epoxy Intermediate ~~Paint~~ Coat

Epoxy intermediate ~~paint~~ coating shall be a two-component ~~coating~~ consisting of an epoxy resin and a curing agent, together with prime and filler pigments, colorants, gellant, leveling agents, and solvents. When mixed, this coating shall be suitable for application over inorganic and organic zinc primers and shall be compatible with a polyurethane finish coat. The color of this coating shall contrast significantly from the other coatings within the coating system.

The mixed ~~paint~~ coating shall be in accordance with the following requirements:

[-----]

COMMENTS AND ACTION

619-B-321 BRIDGE PAINTING

DISCUSSION:

Motion:	Action:
Second:	<input type="checkbox"/> Passed as Submitted
Ayes:	<input type="checkbox"/> Passed as Revised
Nays:	<input type="checkbox"/> Withdrawn
FHWA Approval:	
<hr/>	
2024 Standard Specifications Sections: 909.02(a)3 pg. 1043.	<input type="checkbox"/> 2026 Standard Specifications
	<input type="checkbox"/> Revise Pay Items List
	<input type="checkbox"/> Notification to Designers if change is <u>not</u> addressed by RSP
Recurring Special Provisions or Plan Details: 619-B-321 BRIDGE PAINTING	<input type="checkbox"/> Create RSP (No. __) Effective:
Standard Drawing affected: NONE	<input type="checkbox"/> Revise RSP (No. __) Effective:
Design Manual Chapter: NONE	<input type="checkbox"/> Standard Drawing Effective:
GIFE Section: NONE	<input type="checkbox"/> Create RPD (No. __) Effective:
	<input type="checkbox"/> GIFE Update
	<input type="checkbox"/> Frequency Manual Update
	<input type="checkbox"/> SiteManager Update

PROPOSAL TO STANDARDS COMMITTEE

PROBLEM(S) ENCOUNTERED: The current USP “Trucks for Advanced Queue Awareness” has recently been updated with additional details. The current USP is being utilized with enough frequency that conversion to an RSP is needed.

PROPOSED SOLUTION: Revise details of the USP to reflect current deployment best practices and equipment requirements and convert to an RSP.

APPLICABLE STANDARD SPECIFICATIONS: 801

APPLICABLE STANDARD DRAWINGS: N/A

APPLICABLE DESIGN MANUAL SECTION: N/A

APPLICABLE SECTION OF GIFE: N/A

APPLICABLE RECURRING SPECIAL PROVISIONS: N/A

PAY ITEMS AFFECTED: 801-XXX Queue Truck

APPLICABLE SUB-COMMITTEE ENDORSEMENT: n/a

IF APPROVED AS RECURRING SPECIAL PROVISION OR PLAN DETAILS, PROPOSED BASIS FOR USE:
As determined necessary by the Project Designer’s Queue Analysis in accordance with IDM 503 – 2.07 and inclusion in the Traffic Management Plan, and in accordance with an approved IHCP exception mitigation requirement.

IMPACT ANALYSIS (attach report): Attached

Submitted By: Joe Novak

Title: State Construction Engineer

Organization: INDOT Construction Management

Phone Number: 317-501-7805

Date: 12/08/23

IMPACT ANALYSIS REPORT CHECKLIST

Explain the business case as to why this item should be presented to the Standards Committee for approval. Answer the following questions with Yes, No or N/A.

Does this item appear in any other specification sections? N

Will approval of this item affect the Approved Materials List? N

Will this proposal improve:

Construction costs? N/A

Construction time? N/A

Customer satisfaction? Y

Congestion/travel time? Y

Ride quality? N/A

Will this proposal reduce operational costs or maintenance effort? N/A

Will this item improve safety:

For motorists? Y

For construction workers? Y

Will this proposal improve quality for:

Construction procedures/processes? N/A

Asset preservation? N/A

Design process? N/A

Will this change provide the contractor more flexibility? N/A

Will this proposal provide clarification for the Contractor and field personnel? N/A

Can this item improve/reduce the number of potential change orders? N/A

Is this proposal needed for compliance with:

Federal or State regulations? N

AASHTO or other design code? N

Is this item editorial? N

Provide any further information as to why this proposal should be placed on the Standards Committee meeting Agenda: N/A

REVISION TO RECURRING SPECIAL PROVISIONS

801-T-XXX PROTECT THE QUEUE TRUCKS (proposed new)

801-T-XXX PROTECT THE QUEUE TRUCKS

(Adopted xx-xx-24)

Description

This work shall consist of strategic and ongoing placement, operation, and repositioning of designated Protect the Queue, PTQ, trucks for advanced queue protection of the work zones in accordance with 105.03, to provide advance warning of the traffic queue where stopped or slowed traffic presents risks to motorists and workers.

This work shall include PTQ trucks and operators who are actively assessing the queue, providing a designated graphic and message, and repositioning the vehicle to provide awareness of the traffic queue resulting from construction operations.

Materials

Materials shall be in accordance with 801.02, 919, and as described herein.

Quality Control

(a) Traffic Quality Control Means and Methods Coordination Submittal, TQCMMS

The TQCMMS is a plan that describes how PTQ trucks will be implemented for a given phase of the work zone. For each phase and direction of work, the Contractor shall submit a TQCMMS to the Engineer. A template TQCMMS form is available at the Department's Queue Awareness Program website.

For each phase of construction, the Contractor shall meet with the Engineer to review their plan to deploy PTQ trucks prior to preparing the TQCMMS. Each TQCMMS shall be prepared in accordance with the Temporary Traffic Control Plan, TTCP, and Department Standards. The TQCMMS shall consider the predicted lengths and durations of the queues listed in the Contract Information Book. If queue predictions are not available, the Engineer will provide initial placement locations upon request.

The TQCMMS shall incorporate the configuration of the work zone, including detour routes and interchange ramp control, and provide proposed initial locations for deployment and the staging of PTQ trucks in standby for each day of work. Details shall include start times, initial truck placements, anticipated durations of daily PTQ truck deployments, the planned schedule of deployment, in either calendar days or workdays, and any other specific details discussed between the Engineer and the Contractor prior to submittal.

The Contractor shall submit a TQCMMS and obtain concurrence from the Engineer with the submittal before beginning each phase of work. The Engineer may request revision and provide detailed guidance. The Engineer may also request a resubmission as conditions change. A copy of each TQCMMS document shall be retained by the Contractor, kept in Department project files, and delivered via E-mail to the Department's Traffic Management Center at INDYTMC@indot.in.gov.

REVISION TO RECURRING SPECIAL PROVISIONS

801-T-XXX PROTECT THE QUEUE TRUCKS (proposed new)

(b) Operator Training

PTQ truck operators shall view the Department's Training Video for Queue Awareness available on the Department's Queue Awareness Program website. Upon completion of the training, PTQ truck operators shall fill out, sign, date and submit the Statement of Affirmation form as confirmation that they have completed the training and to affirm their agreement to adhere with the practices discussed in the training and herein. A copy of the signed affirmation form shall be provided to the Engineer. The form is available at the Department's Queue Awareness Program website.

Equipment

PTQ trucks shall consist of a commercial chassis truck with at least 16,000 LB GVWR and shall comply with length requirements designated in IC 9-20-3-4. All PTQ trucks shall be as approved in advance by the Engineer prior to initial deployment on the Project.

(a) Queue Warning Features

In accordance with the PTQ Truck Detail, all PTQ trucks shall include queue warning features consisting of the following equipment:

1. "BE PREPARED TO STOP" Sign

A "BE PREPARED TO STOP" sign, 96 in. wide and 48 in. tall, shall be secured to the vehicle in a manner that ensures the safe operation of the vehicle at highway speeds. The sign shall be in accordance with 919 for traffic sign materials, and shall meet the following additional requirements:

Alternating red and yellow stripes, 6 in. wide, 3M™ Diamond Grade™ Emergency Vehicle Markings 983-71NL and 983-72NL or equivalent. The stripes shall be installed in an upside down "V" fashion in accordance with emergency vehicle marking schemes, as shown on the PTQ Truck Detail. To ensure a robust color, printed sign material shall not be used.

A 30 in. W3-4 "BE PREPARED TO STOP" sign shall be mounted in the center of the alternating red and yellow stripes described above. The sign shall be in accordance with 919 for traffic sign materials. The color shall be FLUORESCENT PINK in accordance with Chapter 6I of the MUTCD.

These signs shall be configured in a manner that does not interfere with brake and reverse lighting ensuring safe operation.

2. Lighting Package on the "BE PREPARED TO STOP" Metal Sign

A lighting package on the "BE PREPARED TO STOP" metal sign shall be distinct from the standard construction lighting package on the PTQ truck and shall meet the following requirements:

Four, Whelen Strip-Lite Plus Series SmartLED® WARNING DUO Model: PSD02FCR 12V RED/WHT flasher lights, or equivalent, shall be installed in accordance with the PTQ Truck Detail.

The operation of the flasher lights shall be managed by a Whelen ULF44, 4 Channel LED Flasher device. The lights shall be placed in solid mode to allow the flasher to operate properly using the ULF44 device. The ULF44 flasher shall be set to operate the ActionFlash 41 pattern.

REVISION TO RECURRING SPECIAL PROVISIONS

801-T-XXX PROTECT THE QUEUE TRUCKS (proposed new)

The flasher lights shall be operable from inside the vehicle using conventional wiring or wireless devices. Lighting packages shall include a dawn-to-dusk dimmer operation, managed from the Whelen Flasher, to avoid excessive lighting during nighttime operations.

3. HAAS Transmitter

A HAAS Transmitter shall be included to report activity to the WAZE TRAFFIC APPLICATIONS. The HAAS transmitter shall be configured to report activity only when the PTQ truck is actively warning motorists of the presence of queue and while the "BE PREPARED TO STOP" sign is visible to motorists with the Whelen lighting package active.

When queue warning features are inactive, the lighting package shall be off, the HAAS system deactivated, and the metal sign stowed or covered so it is not visible to traffic.

(b) Other features

Other features that shall be equipped on all PTQ trucks include:

1. Retractable Truck-mounted Attenuator

The retractable truck-mounted attenuator shall be suitable for a commercial chassis, in accordance with the applicable attenuator manufacturer specifications. Trailer attenuators are prohibited.

2. Truck-mounted Changeable Message Sign

The truck-mounted changeable message sign shall be a WANCO Model WVMB Large Display, or equivalent. The changeable message sign shall be positioned so that it does not cover the "BE PREPARED TO STOP" sign and shall be in accordance with the MUTCD.

3. Rear Camera with Monitor

A rear camera with monitor capable of continuous operation allowing the PTQ truck operator to continuously monitor approaching traffic.

Each truck mounted attenuator shall meet MASH or NCHRP 350 Test Level 3 or higher requirements. A copy of the FHWA eligibility letter for each truck mounted attenuator model shall be provided to the Engineer prior to use.

Construction Requirements

Unless defined otherwise in the contract, two PTQ trucks in each direction shall be provided where PTQ trucks are protecting the queue.

PTQ trucks shall be deployed in accordance with the TQCMMCS for each phase of construction. Start times and initial truck placement shall be confirmed either daily with the Engineer, as agreed at the pre-construction conference, or as agreed during the execution of the contract.

The Contractor shall provide notice to the Department and the Indiana State Police, ISP, three working days prior to commencing work which may develop a queue, necessitating a need for PTQ trucks. The Contractor's notice shall include: the work location, work start and end times, work date, the anticipated queue locations, and the anticipated queue start and end times.

REVISION TO RECURRING SPECIAL PROVISIONS

801-T-XXX PROTECT THE QUEUE TRUCKS (proposed new)

A queue is a congested line of vehicles, stopped or traveling at a significantly lower speed than the posted speed, due to a construction zone, road hazard, or other atypical event. A queue is visually confirmed by significant deceleration or speed delta in the normal flow of traffic as supported by the presence of widespread brake lights. A PTQ truck's queue warning features shall only be visible to motorists when a queue exists or is beginning to form. Deployed PTQ truck operators shall not activate the queue warning features until a queue begins to form, as supported by the presence of a significant deceleration in the normal flow of traffic and widespread brake lights. Once a queue forms, all queue warning features shall be activated. When a queue is no longer present during a scheduled deployment, PTQ trucks shall remain in standby for the remainder of the approved period or until the queue returns.

(a) When Queue is Present

When a queue is present, PTQ truck operators shall activate all queue warning features and activate the appropriate message on the PTQ truck changeable message sign in accordance with the "Changeable Message Sign Messaging" guidance herein.

The initial placement of the primary PTQ truck, the one closest to the work zone, shall be approximately 1/4 mile to 1/2 mile in advance of where queuing is anticipated to form, or as directed by the Engineer. Whenever possible, the primary PTQ truck shall be located within the shoulder that is on the same side of the road where work is being performed. When the PTQ truck cannot be positioned on the same side of the road where work is being performed, unique messaging shall be provided, as approved by the Engineer. Often the initial location where the queue will form is the point of restriction, for example at the start of a lane merge.

The initial placement of the secondary PTQ truck shall be approximately two miles in advance of the primary PTQ truck with its Queue Warning Features deactivated. When near live traffic, construction lighting and appropriate messaging shall be activated. The Contractor shall confirm the locations of initial deployments with the Engineer.

Once in place, PTQ truck operators shall actively monitor traffic flow and prepare to reposition the PTQ trucks as necessary to continuously maintain an optimal position relative to the queue as it grows and shrinks. As a queue develops, the primary PTQ truck shall maintain a distance of approximately 1/4 mile to 1/2 mile in advance of observed braking before the back of queue. Note that once a queue develops and braking begins, the placement of the primary PTQ truck is now determined relative to the location of the braking rather than the back of queue. The secondary PTQ truck shall maintain a position approximately two miles in advance of the primary PTQ truck.

If the queue rapidly expands to where the point that braking is observed to occur within a few seconds of passing the primary PTQ truck, the primary PTQ truck shall signal the secondary PTQ truck to move into an appropriate position, approximately 1/4 to 1/2 mile in advance of the primary PTQ truck, and activate queue warning features and messaging thereby becoming the primary PTQ truck. The overtaken PTQ truck shall then deactivate all queue warning features and be repositioned into the

REVISION TO RECURRING SPECIAL PROVISIONS

801-T-XXX PROTECT THE QUEUE TRUCKS (proposed new)

secondary PTQ truck position. Once in the secondary PTQ truck position, the overtaken PTQ truck shall then function as the secondary PTQ truck maintaining a distance of approximately two miles in advance of the primary PTQ truck.

(b) When Queue is Not Present

When no queue is present, PTQ trucks shall deactivate all queue warning features and be repositioned to a location designated in the TQCMCS. Queue truck operators shall notify the Engineer and be available by phone to receive instructions.

While deactivated, the PTQ truck operators shall monitor traffic conditions and the location of the back of queue from their PTQ truck by using the Department's DeltaSpeed tool or Google Maps, google.com/maps, with the Traffic Layer activated. When queue is observed, PTQ truck operators shall notify the Engineer and resume active queue protection as described herein. A link to the Department's DeltaSpeed tool and other resources are available at the Department's Protect the Queue program website.

(c) Changeable Message Sign Messaging

The default message displayed on the changeable message sign during active queue awareness deployment shall be "SLOW TRAFFIC AHEAD".

Other unique messages or graphics, such as an arrow, shall be pre-programmed as options and may be used when directed by the Engineer, as approved in the TQCMCS, or as directed by the Department's Traffic Management personnel. This shall include cases of use where messaging may be appropriate, but Queue Warning Features are disabled. Unique messages, such as "SHIFT RIGHT" for the case where there is insufficient room to place a PTQ truck on the left shoulder in advance of work that would be performed in the left lane, may be used when deemed appropriate by the Engineer.

Method of Measurement

PTQ trucks will be measured by the number of days that each unit is deployed. A day for the purpose of payment will be a 12 hour continuous period. Additional time will be paid in 1/12 day, one hour, increments.

Basis of Payment

The accepted quantities of PTQ trucks will be paid for at the contract unit price for each truck per day. Payment will be made only once for each day of use, regardless of the number of times the PTQ truck is moved to accommodate different phases of traffic maintenance or construction operations as shown in the contract.

Payment will be made under:

Pay Item	Pay Unit Symbol
PTQ Truck.....	DAY

The cost of all labor, equipment and all incidental work shall be included in the cost of the pay item. The cost of furnishing the PTQ truck, the "BE PREPARED TO STOP" sign, the lighting package on the "BE PREPARED TO STOP" sign, the transmitter reporting activity to WAZE TRAFFIC

REVISION TO RECURRING SPECIAL PROVISIONS

801-T-XXX PROTECT THE QUEUE TRUCKS (proposed new)

APPLICATIONS, the retractable truck-mounted attenuator, the truck-mounted changeable message sign, and the rear camera with a monitor shall be included in the cost of the pay item. No additional payment will be made for maintenance, repairs, or replacement of PTQ trucks that are damaged or become inoperable.

PTQ Truck Detail

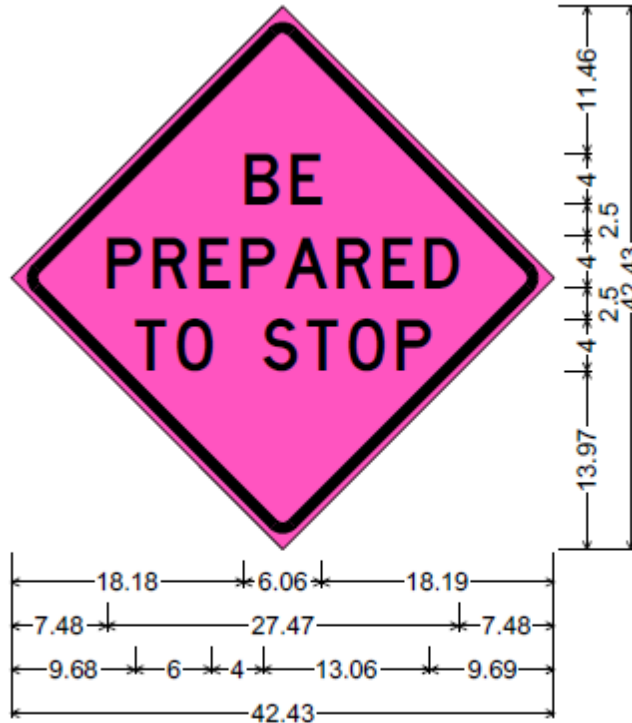

Identifier : W3-4_30x30

30.00" across sides 0.75" Border, 0.50" Indent, Black on Pink;

"BE" D; "PREPARED" D; "TO STOP" D;

REVISION TO RECURRING SPECIAL PROVISIONS

801-T-XXX PROTECT THE QUEUE TRUCKS (proposed new)

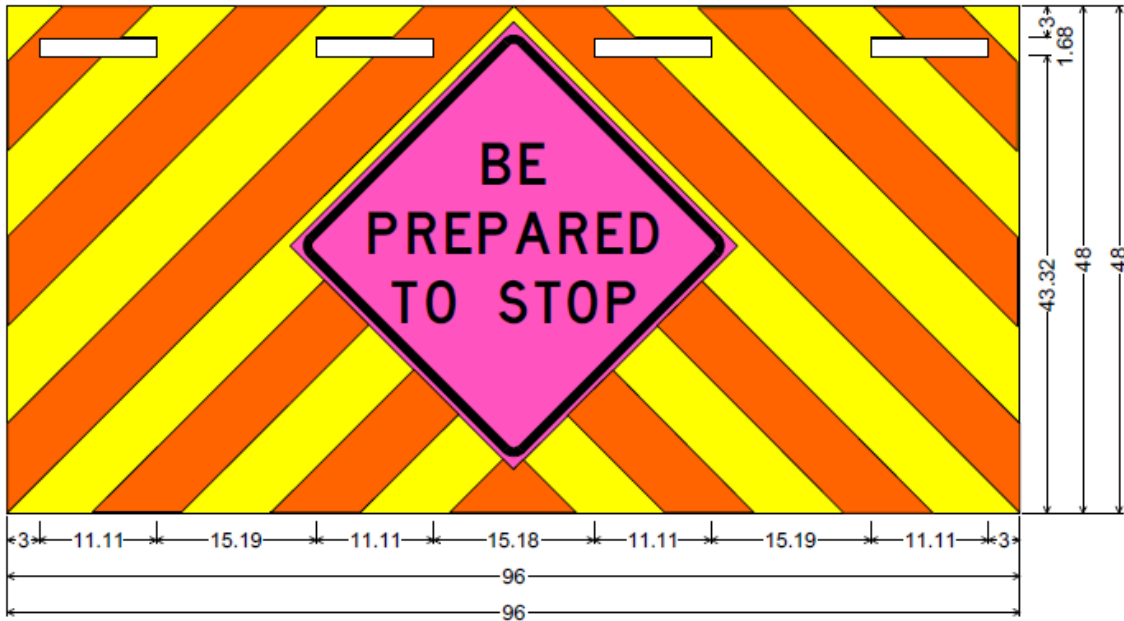

Identifier : 6" Chevrons

No border, Yellow;

Rectangle White; Rectangle White; Rectangle White; Rectangle White; W3-4_30x30;

AGEL

COMMENTS AND ACTION

801-T-XXX PROTECT THE QUEUE TRUCKS (proposed new)

Motion:	Action:
Second:	<input type="checkbox"/> Passed as Submitted
Ayes:	<input type="checkbox"/> Passed as Revised
Nays:	<input type="checkbox"/> Withdrawn
FHWA Approval:	
2024 Standard Specifications Sections: 801 begin pg. 867.	<input type="checkbox"/> 2026 Standard Specifications
	<input type="checkbox"/> Revise Pay Items List
	<input type="checkbox"/> Notification to Designers if change is <u>not</u> addressed by RSP
Recurring Special Provisions or Plan Details: (proposed new)	<input type="checkbox"/> Create RSP (No. __) Effective:
Standard Drawing affected: NONE	<input type="checkbox"/> Revise RSP (No. __) Effective:
Design Manual Chapter: NONE	<input type="checkbox"/> Standard Drawing Effective:
GIFE Section: NONE	<input type="checkbox"/> Create RPD (No. __) Effective:
	<input type="checkbox"/> GIFE Update
	<input type="checkbox"/> Frequency Manual Update
	<input type="checkbox"/> SiteManager Update